

GBN GOVERNMENT POLYTECHNIC NILOKHERI

Branch: ECE

Semester: 5th Sem.

Subject: Instrumentation

MEASUREMENTS

Measuring System

- A Measuring system exists to provide information about the physical value of some variable.
- Measurement: It is an act or the result of a quantitative comparison between a given quantity and a quantity of same kind selected as a unit. Or
- Measurement is the process by which one can convert physical parameters to meaningful numbers.
- Measuring instruments: It is a device used for comparing the unknown quantity with the unit or standard quantity.

Methods of measurements

- **Direct methods:** In these methods, the unknown quantity is directly compared against a standard quantity. The result is expressed as a numerical number and a unit. E.g. measurement of resistance using ohmmeter or measurement of physical quantities like length, mass time etc..
- **Indirect methods:** Measurement by direct methods are not always possible or feasible and practicable. Generally, in indirect method we use an instrument which is called transducer. This instrument is very useful for indirect measurement because transducer element convert the physical quantity (which is to be measured) in an analogous form. E.g. measurement of resistance with the help of voltmeter and ammeter ($R = V/I$).

Importance Of Measurement

- The advancement of science and technology is dependent upon the progress in measurement techniques.
- With these advancement, new phenomena and relationships are discovered and make new types of measurements imperative.
- The measurement confirm the validity of a hypothesis and also add to its understanding.
- This result in an unending chain which leads to new discoveries that require more, new and sophisticated measurement techniques.
- The two major functions of all branches of engineering are: i) Design of equipment and processes. ii) Proper operation and maintenance of equipment and processes.
- Both these functions require measurements because proper and economical design, operation & maintenance require a feedback of information.
- Measurements play a significant role in achieving goals and objectives of engineering because of the feedback information supplied by them.

Elements of a Measurement System

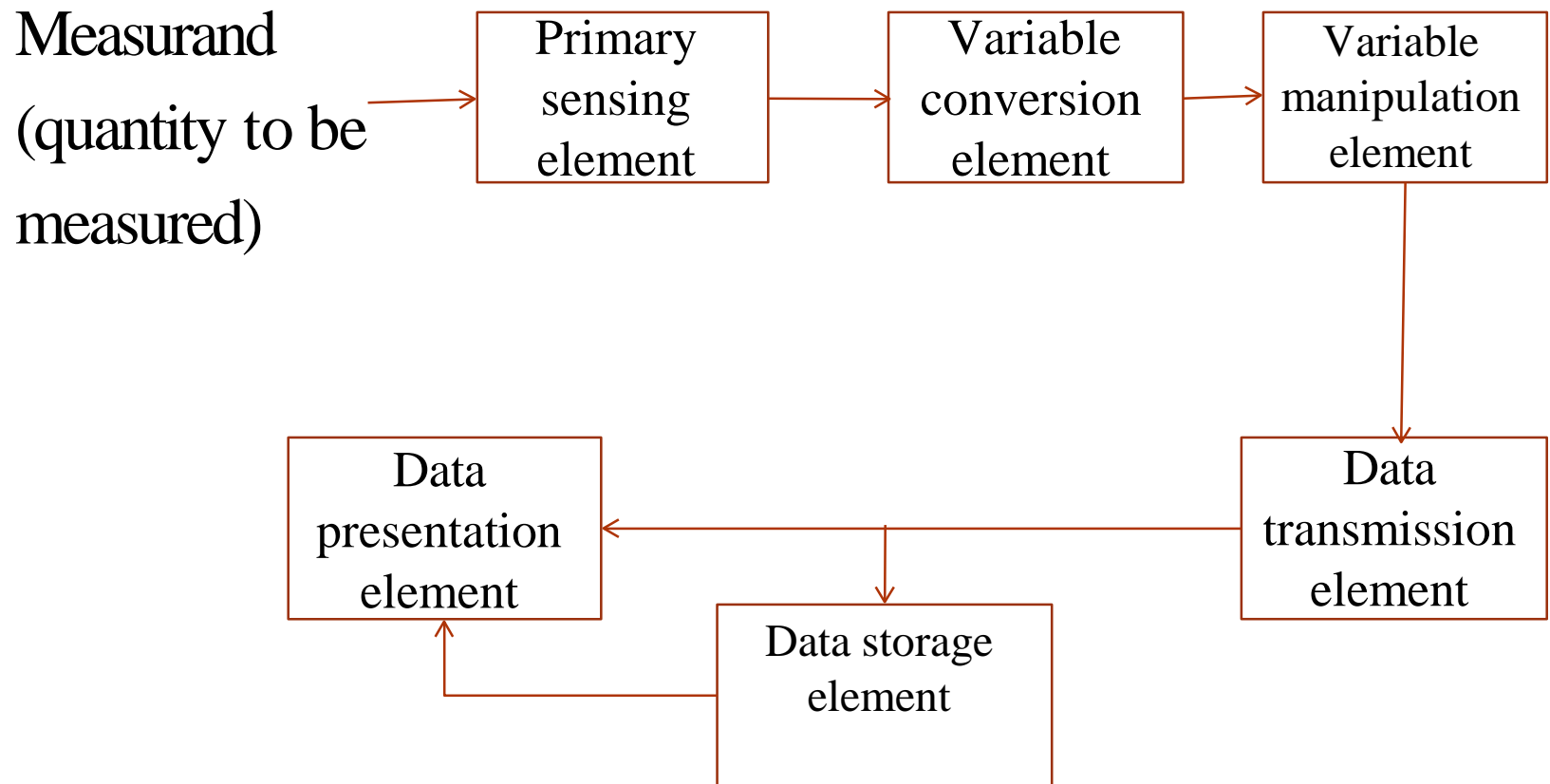

Signal conditioning

- The intermediate state between 1st stage (i.e. detector transducer stage) and 3rd stage (i.e. signal presentation stage) of a measurement system is called signal conditioning stage.
- Data/signal is either converted from one form to another or it is manipulated as per the requirement.
- Signal conditioning means data processed in terms of linear operation or non-linear operations.
- Linear processes involves— amplification, attenuation, integration, differentiation, addition and subtraction etc.
- Non-linear processes involves- modulation, demodulation, sampling, filtering, squaring etc.

Signal conditioning(cont'd)

- To do signal conditioning various equipments are used called signal conditioning or data acquisition equipment.
- These equipment in many situation are an excitation and amplification for passive transducers.
- The excitation source may be DC or AC source.
- On the basis for this, signal conditioning can be classified in two categories i.e.
 - I. DC signal conditioning system.
 - II. AC signal conditioning system.

DC signal conditioning system

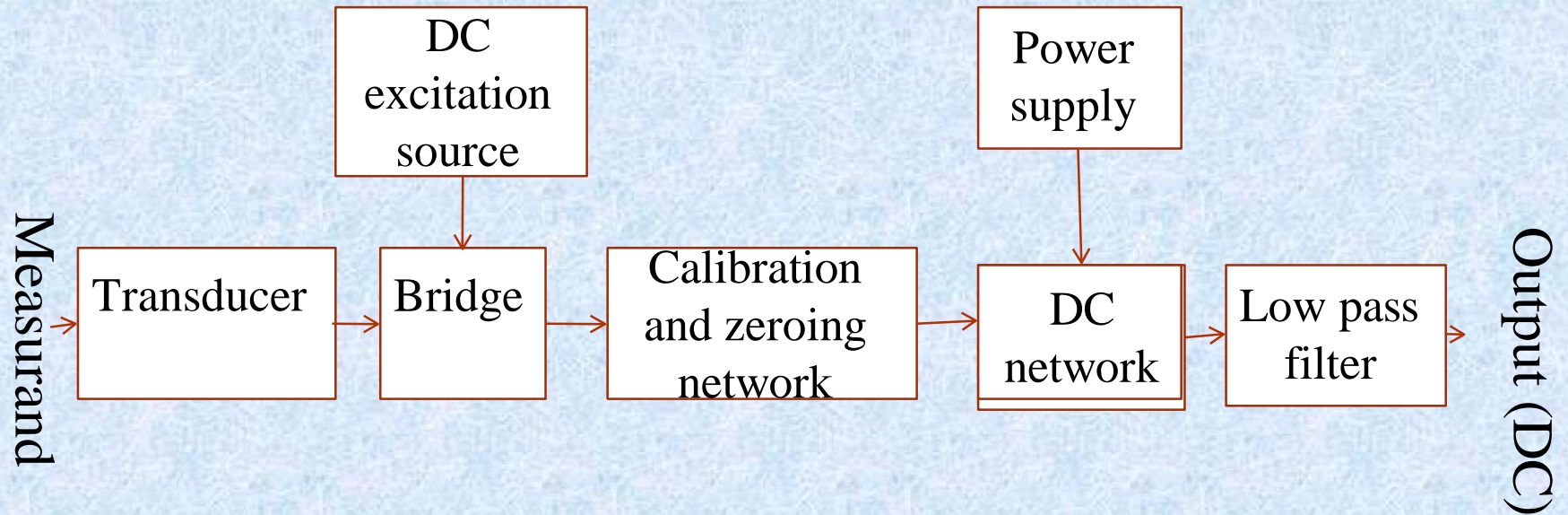

Desirable characteristics of a DC amplifier are:

1. It may need balanced differential inputs giving a high CMRR.
2. It should have an extremely good thermal and long terms stability.

Advantages of DC amplifier are:

1. It is easy to calibrate at low frequencies.
2. It is able to recover from an overload condition unlike its AC counterpart.

Disadvantage of a DC amplifier is that it suffers from the problem of drift. Thus low frequency spurious signals come out as data information. For this reason special low drift dc amplifier are used.

AC signal conditioning system

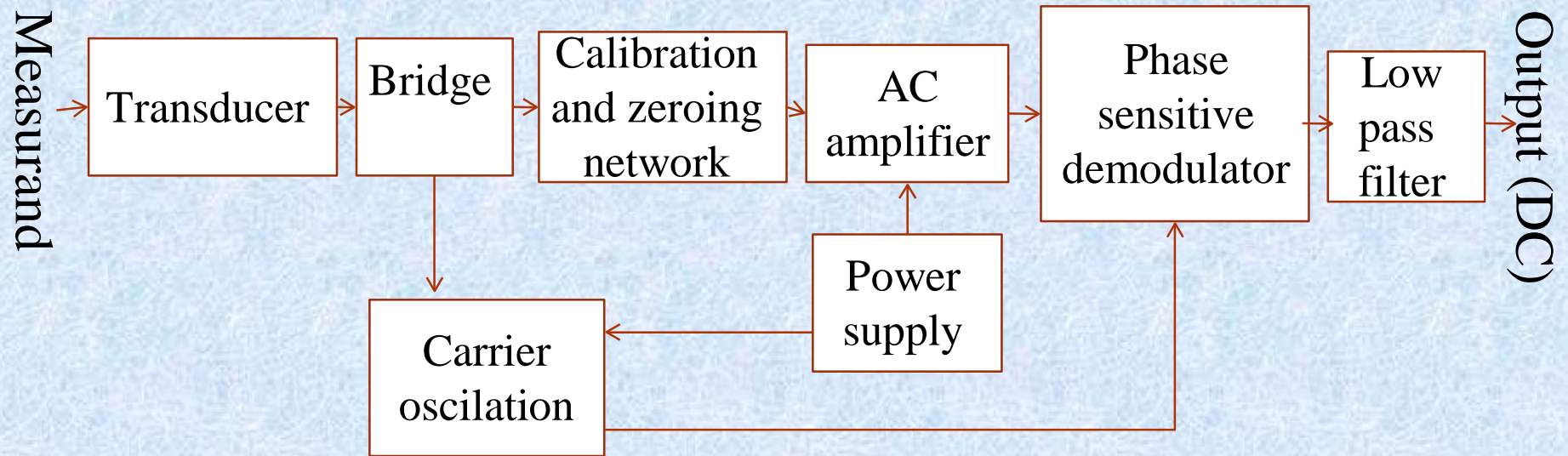

- Variable resistance or variable reactance transducers
- Carrier frequencies of 50Hz to 200 kHz
- Carrier frequencies 5 to 10 times the signal frequency
- Demodulation is phase sensitive so that the polarity of dc output indicates the direction of the parameter change in the bridge output.
- Carrier system amplifier drift and spurious signal are not of much importance unless they modulate the carrier.
- Difficult to achieve stable carrier oscillation than dc stabilized source.
- Active filter can be used to prevent overloading of ac amplifier

Display Devices

- The last stage of a measurement system is the data presentation stage which consists of display devices.
- In order that the results of a measurement system are meaningful, they must be displayed for instant observation at a later stage is called a display device.
- A display device is an output device for presentation of information in visual or tactile form
- When the input information that is supplied has an electrical signal the display is called an electronic display.
- Display devices can be categorized into:
 - i. Analog instruments/display
 - ii. Digital instruments/display

Analog instruments/display

- These consists of indicating instruments which directly indicate the quantity being measured on the prescribed scale in form of pointer deflection on scale.
- E.g. analog voltmeter, ammeter etc.

Digital instruments/display

- Digital display device directly display on the screen, the quantity being measured or to be presented in the form of numerals/characters.
- The various digital display devices which are commonly used are:
 - LED
 - LCD
 - Seven segment display etc.

LED

- Light emitting diodes are used in LED displays.
- Operation of the LED displays is based on the injection luminescence.
- LED displays are available in many different sizes and shapes.
- Usually LED displays radiate red, orange, yellow or green light.
- They have a wide operating temperature range, are inexpensive, easily interfaced to digital logic, easily multiplexed, do not require high voltages and have fast response time.
- The viewing angle is good and display of arbitrary numbers of digits is easily assembled.

LED

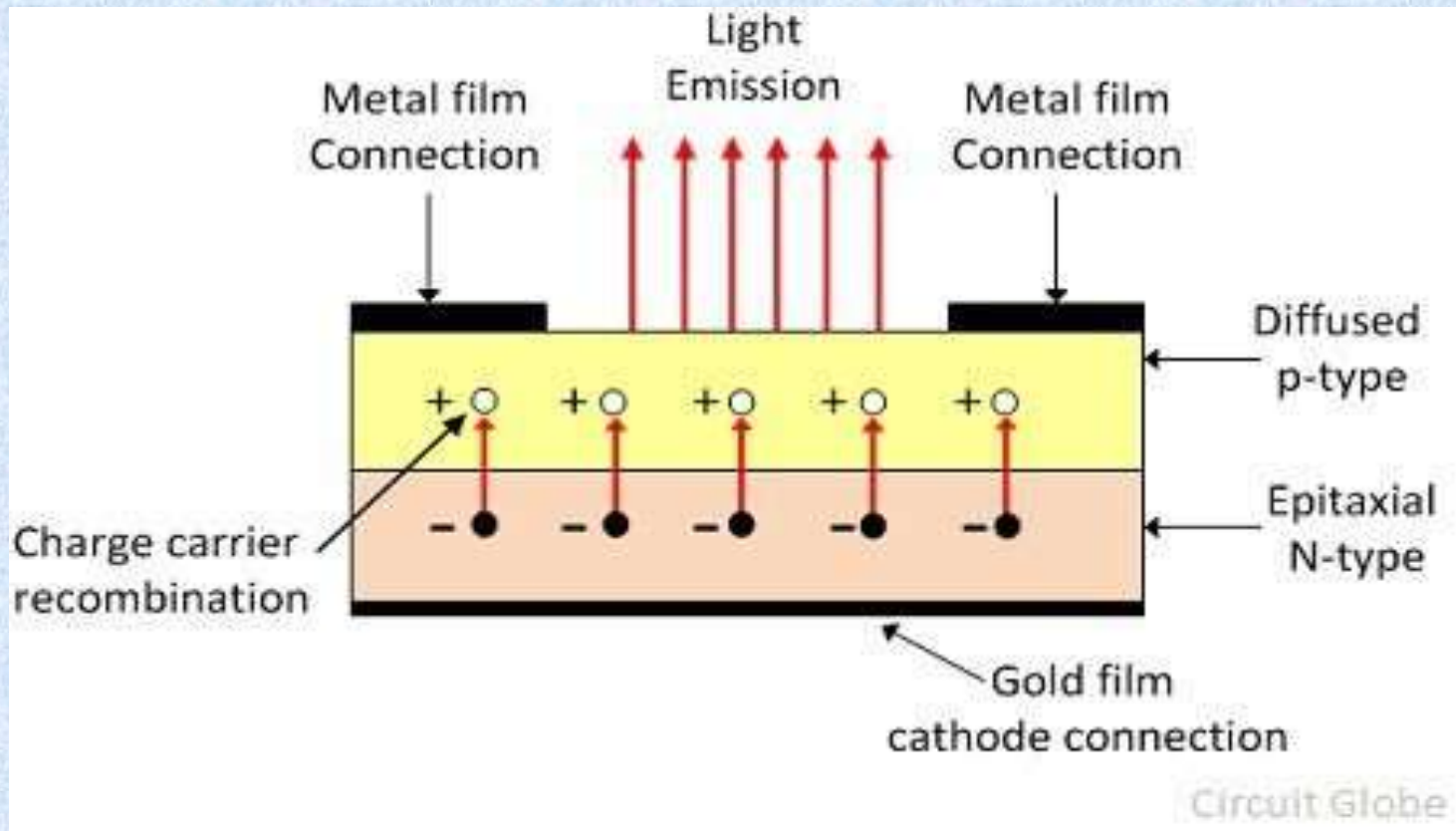

Liquid crystal displays

- LCDs are two types:
 - i. Dynamic scattering type
 - ii. Field effect type

(i) Dynamic scattering type:

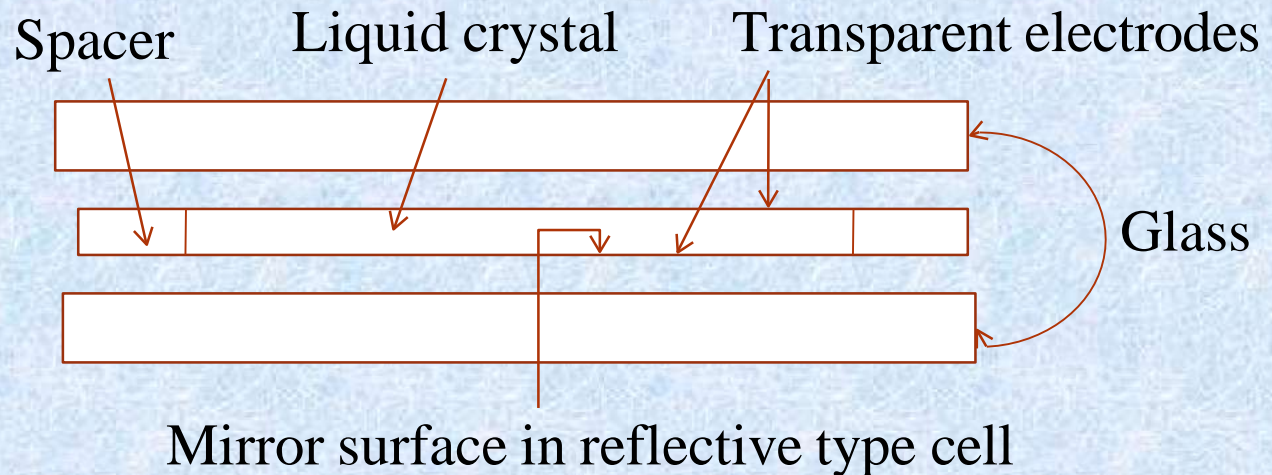

Fig. Liquid Crystal Diode Cell (LCD)

Dynamic scattering type

- The liquid crystal material is so chosen that it shows optical properties of a crystal through they remain in liquid form.
- Between the glass sheets, liquid crystal is layered with transparent electrodes deposited on the inside faces.
- When a potential is applied across the cell, charge carrier flowing through the liquid disrupt the molecular alignment and produce turbulence.
- When liquid is not activated, it is transparent.
- When the liquid is activates, the molecular turbulence causes light to be scattered in all directions and the cell appears to be bright. This phenomenon is called dynamic scattering.

Field effect type

- The construction of field effect type LCD is same as dynamic scattering type with exception that **two polarizing optical filters are placed at inside of each glass sheet.**
- different type of liquid material used.
- The material used here is twisted nematic type which twists the light passing through cell when the later is not energized.
- When the cell is energized no twisting of light takes place and the cell appears dull.

Liquid crystal displays

Transmission LCD displays do not have the reflector and must be provided with rear illumination. They operate in a very similar fashion to the reflective displays.

Colour displays are possible by incorporating colour filters.

An LCD cell consumes only microwatts of power over a thousand times less than LED displays.

LCDs can operate on voltages as low as 2 to 3 V and are easily driven by MOS IC drivers.

LCDs also have their disadvantages. They cannot be seen in the dark, have a limited viewing angle and a limited temperature range.

LED vs. LCD

LED	LCD
LEDs Consume more power than LCDs.	LCD Consumes very less power.
Due to high power requirement, LED requires external interface circuits (called Driver Circuit) when driven from ICs.	LCD can be driven directly from IC chips. Driver Circuits are not required.
The brightness level is very good for LEDs	LCDs have moderate brightness level.
Commercially available LEDs have operating temperature range of -40 to 85 degree Celsius.	comparatively less temperature limit. The temperature range is limited to -20 to 60 degree Celsius.
Life time is around 1,00,000 hours	Due to chemical degradation the life time is 50,000 hours.
The switching time is less than 1ns	Switching time is quite large, so LCDs are slow devices.
LEDs have wide viewing angle. The viewing angle is 150 degree	The viewing angle for LCD is 100 degree
Operating voltage range is 1.5V to 5VDC.	Operating voltage range is 3 to 20 VDC.

Nixie tube

- A nixie tube is an electronic device for displaying numerals or other information, in the form of a glass tube containing multiple cathodes and a wire mesh anode, filled with neon and often a little mercury and/or argon ... at a small fraction of atmospheric pressure. It is a cold-cathode tube (a form of gas filled tube), or a variant of neon lamp.

Nixie Tube

The most common form of nixie tube has ten cathodes in the shapes of the numerals 0 to 9 (and occasionally a decimal point or two), but there are also types that show various letters, signs and symbols. Each cathode can be made to glow in the characteristic neon red-orange color by applying about 170 volts DC at a few mA between a cathode and the anode.

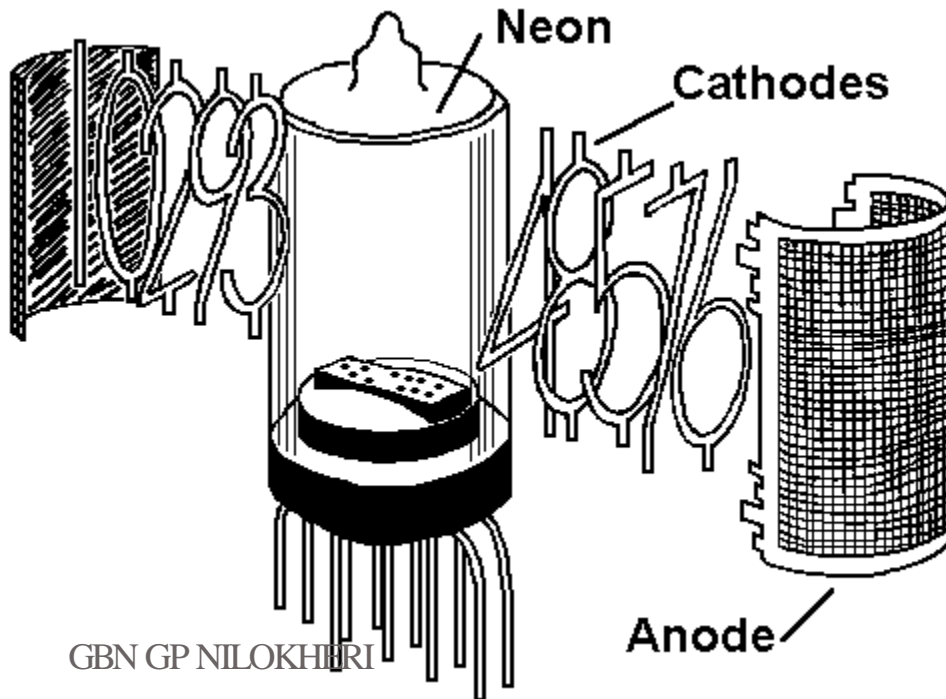

Seven-segment display (SSD)

- “**Seven segment display**”, consists of seven LEDs (hence its name) arranged in a rectangular fashion as shown. Each of the seven LEDs is called a segment because when illuminated the segment forms part of a numerical digit (both Decimal and Hex) to be displayed. An additional 8th LED is sometimes used within the same package thus allowing the indication of a decimal point, (DP) when two or more 7-segment displays are connected together to display numbers greater than ten.
- Seven-segment displays are widely used in digital clocks, electronic meters, basic calculators, and other electronic devices that display numerical information

Common Cathode 7-segment Display

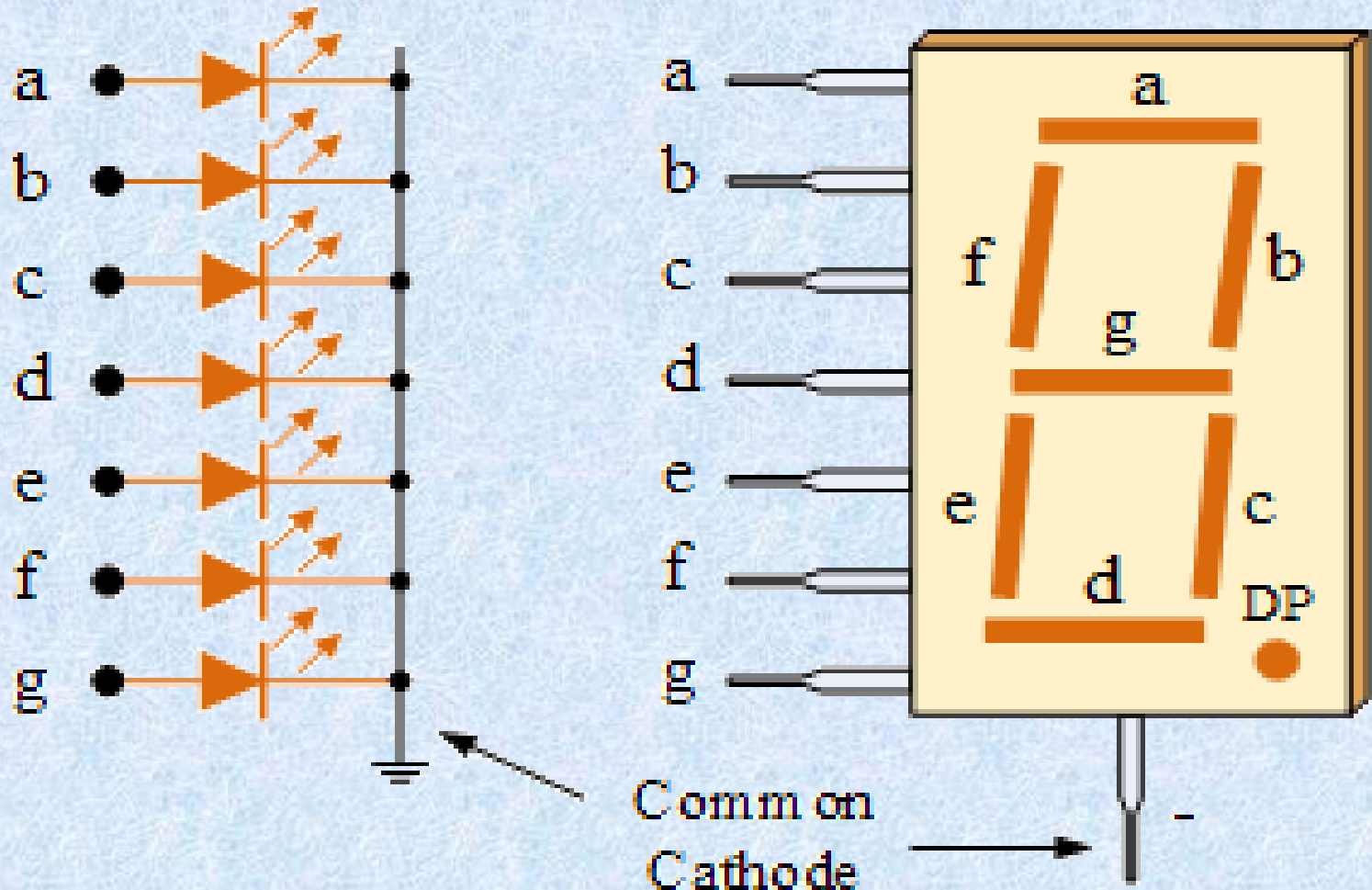

Fourteen and sixteen segments display:

sixteen and fourteen segment displays were some of the few options available for producing alphanumeric characters on calculators and other embedded systems.

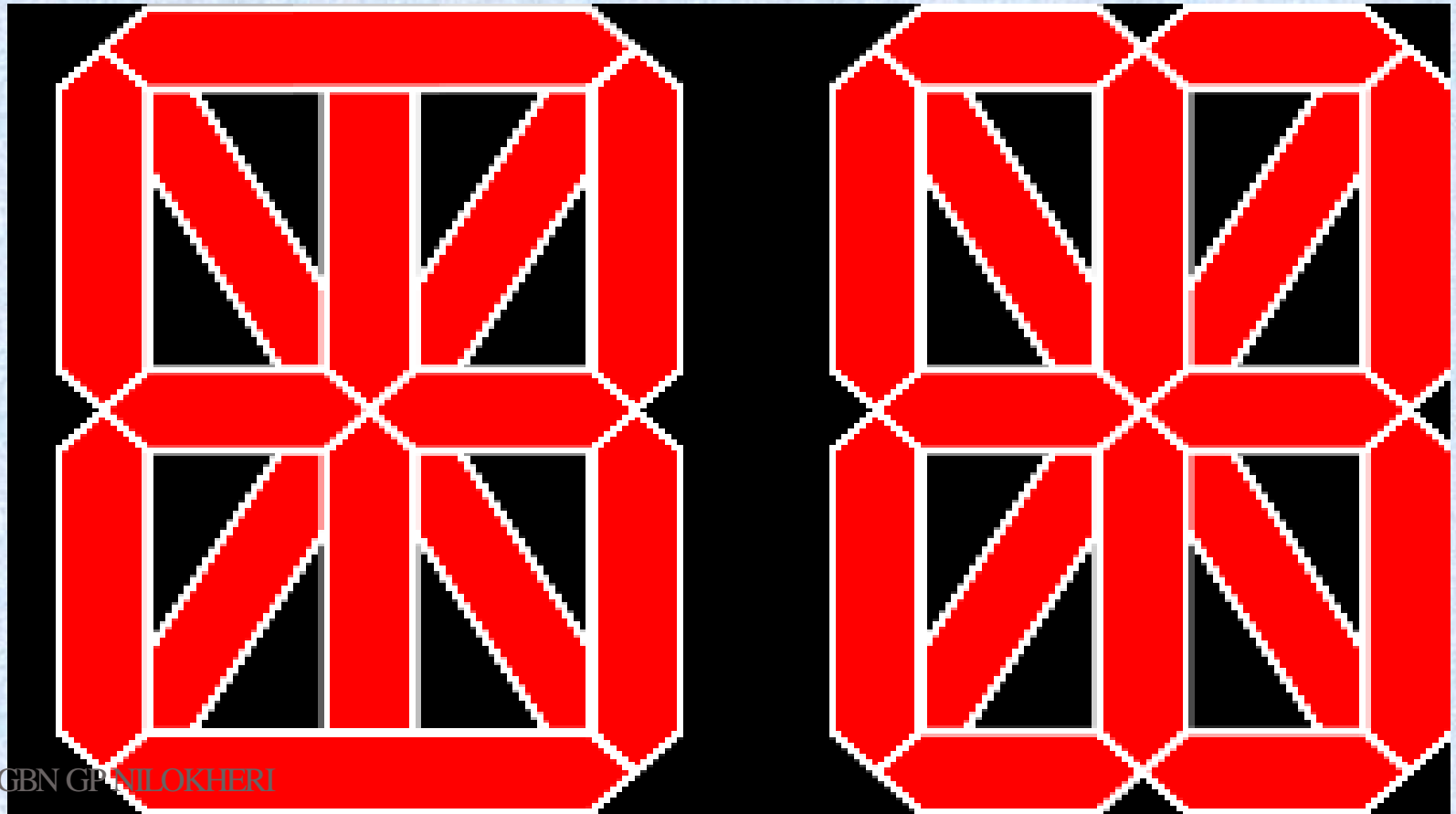

DOT MATRIX

- A dot-matrix display is an electronic digital display device that displays information on machines, clocks and watches, public transport departure indicators and many other devices requiring a simple alphanumeric (and/or graphic) display device of limited resolution.
- The display consists of a dot matrix of lights or mechanical indicators arranged in a rectangular configuration (other shapes are also possible, although not common) such that by switching on or off selected lights, text or graphics can be displayed.
- A common size for a character is 5×7 pixels or 3×5 .
- Dot matrix displays of sufficient resolution can be programmed to emulate the customary seven -segment numeral patterns.
- A larger size is 5×9 pixels, which is used on many Natural Display calculators.

DOT MATRIX



“A Matrix Display in the size 20×2” – This is a classic 5×7 dot matrix LCD used in some early cell phones and vending machines

TRANSDUCERS

Introduction

- Basically transducer is defined as a device, which converts energy or information from one form to another.
- These are widely used in measurement work because not all quantities that need to be measured can be displayed as easily as others.
- A better measurement of a quantity can usually be made if it may be converted to another form, which is more conveniently or accurately displayed.

Introduction(cont'd)

- For example, the common *mercury thermometer* converts variations in temperature into variations in the length of a column of mercury. Since the variation in the length of the mercury column is rather simple to measure, the mercury thermometer becomes a convenient device for measuring temperature.
- Manometer, which detects pressure and indicates it directly on a scale calibrated in actual units of pressure.

Introduction(cont'd)

- Thus the transducer is a device, which provides a usable output in response to specific input measured, which may be physical or mechanical quantity, property or condition.
- The transducer may be mechanical, electrical, magnetic, optical, chemical, acoustic, thermal nuclear, or a combination of any two or more of these.

Mechanical transducers

Advantages:-

- simple and rugged in construction
- cheaper in cost
- accurate and
- operate without external power supplies

Disadvantage:-

- poor frequency response
- requirement of large forces to overcome mechanical friction
- in compatibility when remote control or indication is required

ELECTRICAL TRANSDUCERS

- Mostly quantities to be measured are non-electrical such as temperature, pressure, displacement, humidity, fluid flow, speed etc., but these quantities cannot be measured directly. Hence such quantities are required to be sensed and changed into some other form for easy measurement.
- Electrical quantities such as current, voltage, resistance, inductance and capacitance etc. can be conveniently measured, transferred and stored, and therefore, for measurement of non-electrical quantities these are to be converted into electrical quantities first and then measured.

ELECTRICAL TRANSDUCERS(cont'd)

- The function of converting non-electrical quantity into electrical one is accomplished by a device called the electrical transducer.
- Basically an electrical transducer is a sensing device by which a physical, mechanical or optical quantity to be measured is transformed directly, with a suitable mechanism, into an electrical signal (current, voltage or frequency).
- The production of these signals is based upon electrical effects which may be resistive, inductive, capacitive etc in nature.

BASIC REQUIREMENTS OF A TRANSDUCER

The main function of a transducer is to respond only for the measurement under specified limits for which it is designed. It is, therefore, necessary to know the relationship between the input and output quantities and it should be fixed.

Transducers should meet the following basic requirements:-

- **Ruggedness:** It should be capable of withstanding overload and some safety arrangement should be provided for overload protection.
- **Linearity:** Its input-output characteristics should be linear and it should produce these characteristics in symmetrical way.

Basic Requirements Of a Transducer (cont'd)

- **Repeatability:** It should reproduce same output signal when the same input signal is applied again and again under fixed environmental conditions e.g. temperature, pressure, humidity etc.
- **High Output Signal Quality:** The quality of output signal should be good i.e. the ratio of the signal to the noise should be high and the amplitude of the output signal should be enough.
- **High Reliability and Stability:** It should give minimum error in measurement for temperature variations, vibrations and other various changes in surroundings.

Basic Requirements Of a Transducer (cont'd)

- **No Hysteretic:** It should not give any hysteresis during measurement while input signal is varied from its low value to high value and vice-versa.
- **Residual Deformation:** There should be no deformation on removal of load after long period of application.
- **Range:** The range of the transducer should be large enough to encompass all the expected magnitudes of the measurand.

Basic Requirements Of a Transducer

(cont'd)

- **Sensitivity:** The transducer should give a sufficient output signal per unit of measured input in order to yield meaningful data.
- **Electrical Output Characteristics:** The electrical characteristics-the output impedance, the frequency response, and the response time of the transducer output signal should be compatible with the recording device and the rest of the measuring system equipment.
- **Physical Environment:** The transducer selected should be able to withstand the environmental conditions to which it is likely to be subjected while carrying out measurements and tests.

Basic Requirements Of a Transducer (cont'd)

- **Errors:** The errors inherent in the operation of the transducer itself, or those errors caused by environmental conditions of the measurement, should be small enough or controllable enough that they allow meaningful data to be taken.
- **Good Dynamic Response:** Its output should be faithful to input when taken as a function of time. The effect is analyzed as the frequency response.

Classification Of Transducers

- The transducers may be classified in various ways such as on the basis of electrical principles involved, methods of application, methods of energy conversion used, nature of output signal etc.

1. On the basis of transduction principle involved:

- Resistive
- Inductive
- Capacitive etc.

Classification Of Transducers(cont'd)

- **Primary and Secondary Transducers:**

Transducers, on the basis of methods of applications, may be classified into primary and secondary transducers. When the input signal is directly sensed by the transducer and physical phenomenon is converted into the electrical form directly then such a transducer is called the primary transducer.

2-Primary and Secondary Transducers(cont'd)

- For example a thermistor used for the measurement of temperature fall in this category. The thermistor senses the temperature directly and causes the change in resistance with the change in temperature. When the input signal is sensed first by some detector or sensor and then its output being of some form other than input signals is given as input to a transducer for conversion into electrical form, then such a transducer falls in the category of secondary transducers.

Primary and Secondary Transducers(cont'd)

- For example, in case of pressure measurement, bourdon tube is a primary sensor which converts pressure first into displacement, and then the displacement is converted into an output voltage by an LVDT. In this case LVDT is secondary transducer.

3-Active and Passive Transducers.

- Transducers, on the basis of methods of energy conversion used, may be classified into active and passive transducers.

Active transducers:-

- *Self-generating type transducers i.e. the transducers, which develop their output the form of electrical voltage or current without any auxiliary source, are called the active transducers. Such transducers draw energy from the system under measurement. Normal such transducers give very small output and, therefore, use of amplifier becomes essential. E.g. Thermocouple.*

Active and Passive Transducers(cont'd)

Passive transducers:-

- Transducers, in which electrical parameters i.e. resistance, inductance or capacitance changes with the change in input signal, are called the passive transducers. These transducers require external power source for energy conversion. In such transducer electrical parameters i.e. resistance, inductance or capacitance causes a change in voltages current or frequency of the external power source. These transducers may draw sour energy from the system under measurement. Resistive, inductive and capacitive transducer falls in this category.

4-Analog and Digital Transducers

- Transducers, on the basis of nature of output signal, may be classified into analog and digital transducers.

Analog transducer:-

- converts input signal into output signal, which is a continuous function of time such as thermistor, strain gauge, LVDT, thermo-couple etc.

Digital transducer:-

- converts input signal into the output signal of the form of pulse e.g. it gives discrete output.

Analog and Digital transducers(cont'd)

- These transducers are becoming more and more popular now-a-days because of advantages associated with digital measuring instruments and also due to the effect that digital signals can be transmitted over a long distance without causing much distortion due to amplitude variation and phase shift. Sometimes an analog transducer combined with an ADC (analog-digital converter) is called a digital transducer.

5. Transducers and Inverse Transducers.

Transducer:-

- Transducer, as already defined, is a device that converts a non-electrical quantity into an electrical quantity. For example a thermo-couple, photoconductive cell, pressure gauge, strain gauge etc.

Inverse transducer:-

- An inverse transducer is a device that converts an electrical quantity into a non-electrical quantity. It is a precision actuator having an electrical input and a low-power non-electrical output.

Transducers and Inverse Transducers(cont'd)

- For examples a piezoelectric crystal and transnational and angular moving-coil elements can be employed as inverse transducers. Many data-indicating and recording devices are basically inverse transducers. An ammeter or voltmeter converts electric current into mechanical movement and the characteristics of such an instrument placed at the output of a measuring system are important. A most useful application of inverse transducers is in feedback measuring systems.

Resistive Transducers

- The resistance of a metal conductor is expressed by a simple equation that involves a few physical quantities. The relationship is $R = \rho L / A$.
- where R =resistance; and L =length of conductor; m , A =cross-sectional area of conductor; m^2 , and ρ =resistivity of conductor material; ' Ω -m.
- Any method of varying one of the quantities involved in the above relationship can be the design basis of an electrical resistive transducer.

Potentiometers

- A resistive potentiometer, or simply a pot, (A potentiometer used for the purposes of voltage division is called a pot) consists of a resistance element provided with a sliding contact.
- This sliding contact is called a wiper. The motion of sliding contact may be translatory or rotational.
- Some pots use the combination of the two motions, i.e. translational as well as rotational.
- These potentiometers have their resistive element in the form of helix and thus, are called helipots.

Translational Potentiometers

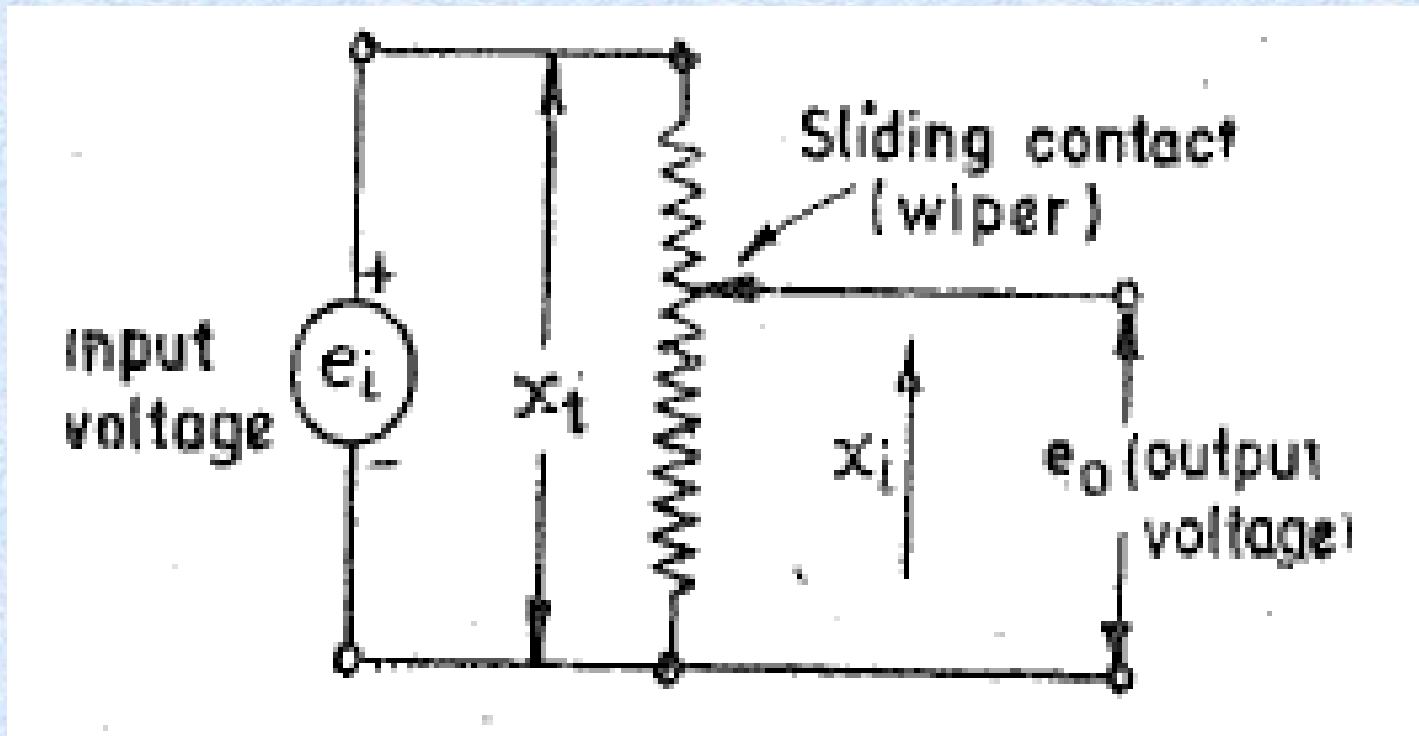

- If the distribution of the resistance with respect to translational movement is linear, the resistance per unit length is R_p/X_t .
- The output voltage under ideal conditions is :

$$e_o = \left(\frac{\text{resistance at the output terminals}}{\text{resistance at the input terminals}} \right) \times \text{input voltage}$$

$$= \left[\frac{(R_p/x_t \times x_i)}{R_p} \right] \times e_i = \frac{x_i}{x_t} e_i$$

- Thus under ideal circumstances, the output voltage varies linearly with displacement

Characteristics of potentiometers

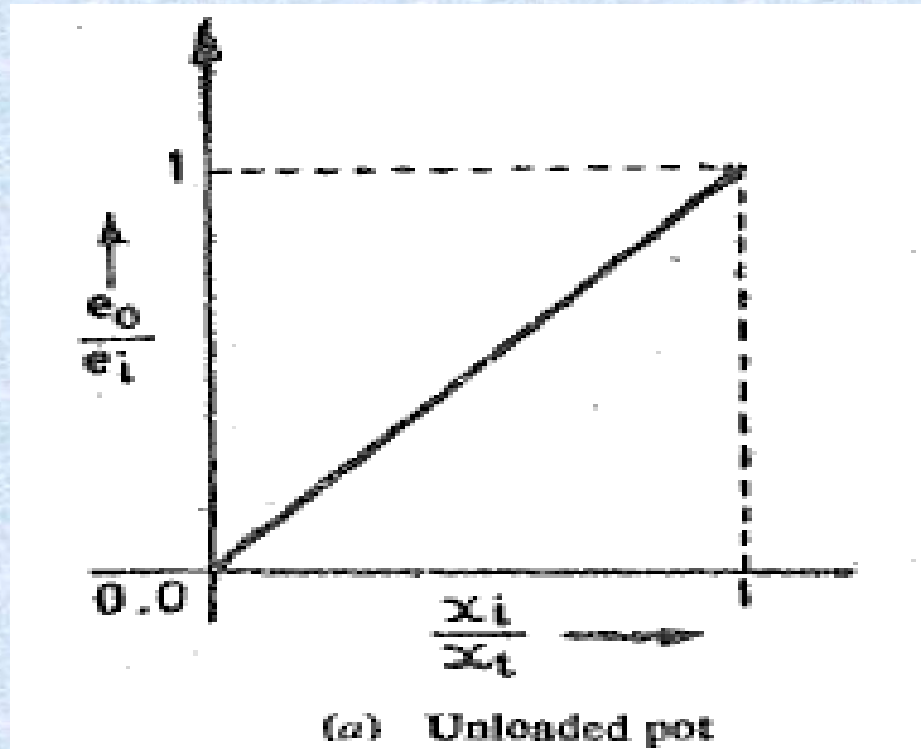

$$\text{Sensitivity } S = \frac{\text{output}}{\text{input}} = \frac{e_o}{x_t} = \frac{e_i}{x_t}$$

- Thus under ideal conditions the sensitivity is constant and the output is faithfully reproduced and has a linear relationship with input. The same is true of rotational motion.

Rotational Potentiometers

Let θ_i = input angular displacement in degrees, and θ_t = total travel of the wiper in degrees

\therefore Output voltage $e_o = e_i / \theta_t / \theta_i$

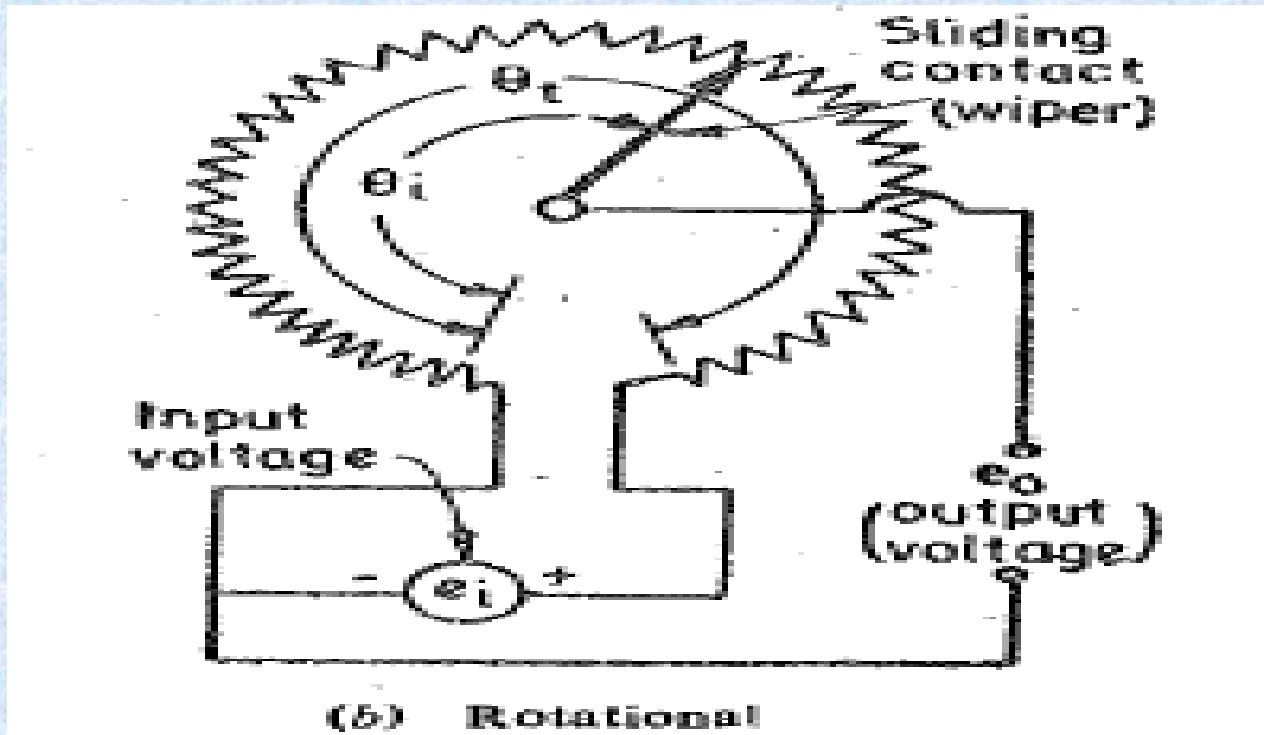

- This is true of single turn potentiometers only.

- Let the resistance of a meter or a recorder monitoring the output be R_m . As explained earlier if the resistance across the output terminals is infinite, we get a linear relationship between the output and the input voltage.
- $e_o = (x_i/x_t)e_i = Ke_i$

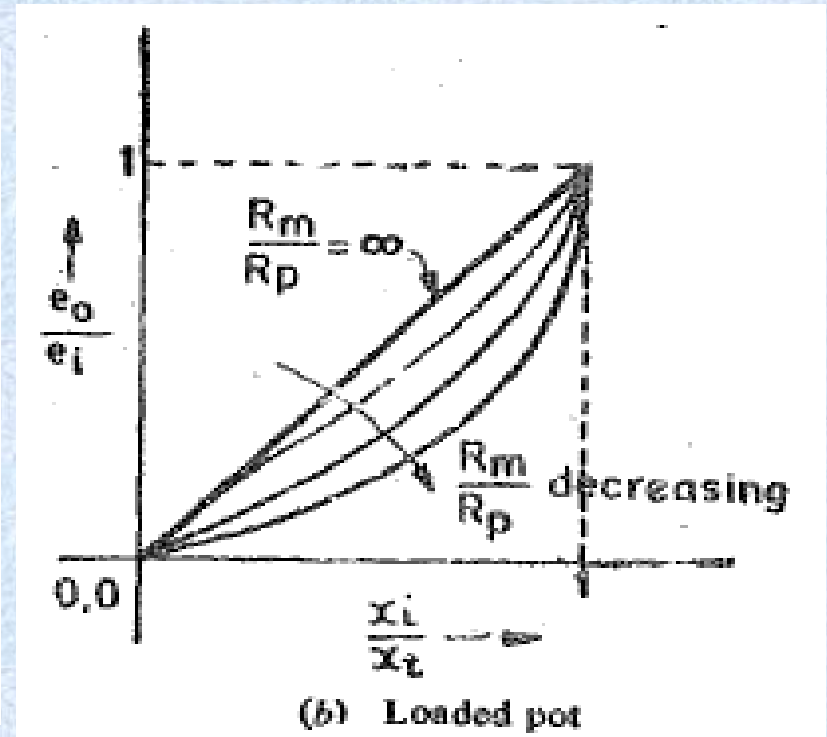
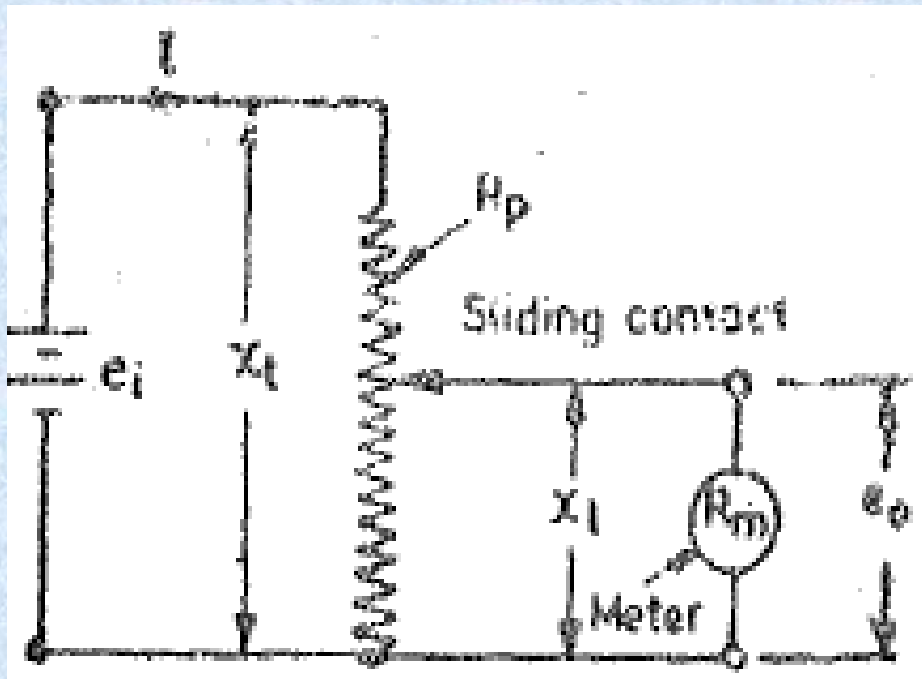

- However, under actual conditions the resistance, R_m , is not infinite. This causes a non-linear relationship between the output and input voltages.

Helipots

- The resolution can be increased by using multi-turn potentiometers. These are called helipots.
- The resistance element is in the form of a helix and the wiper travels along a "lead screw".
- The number of turns is still limited to 200 to 400 per cm but an increase in resolution can be obtained by using a gearing arrangement between the shaft whose motion is to be measured and the potentiometer shaft.
- As an example, one rotation of the measured shaft can cause 10 rotations of the potentiometer shaft. This increases the resolution of the measured shaft motion by 10 times.
- Multi-turn potentiometers are available to about 60 turns.

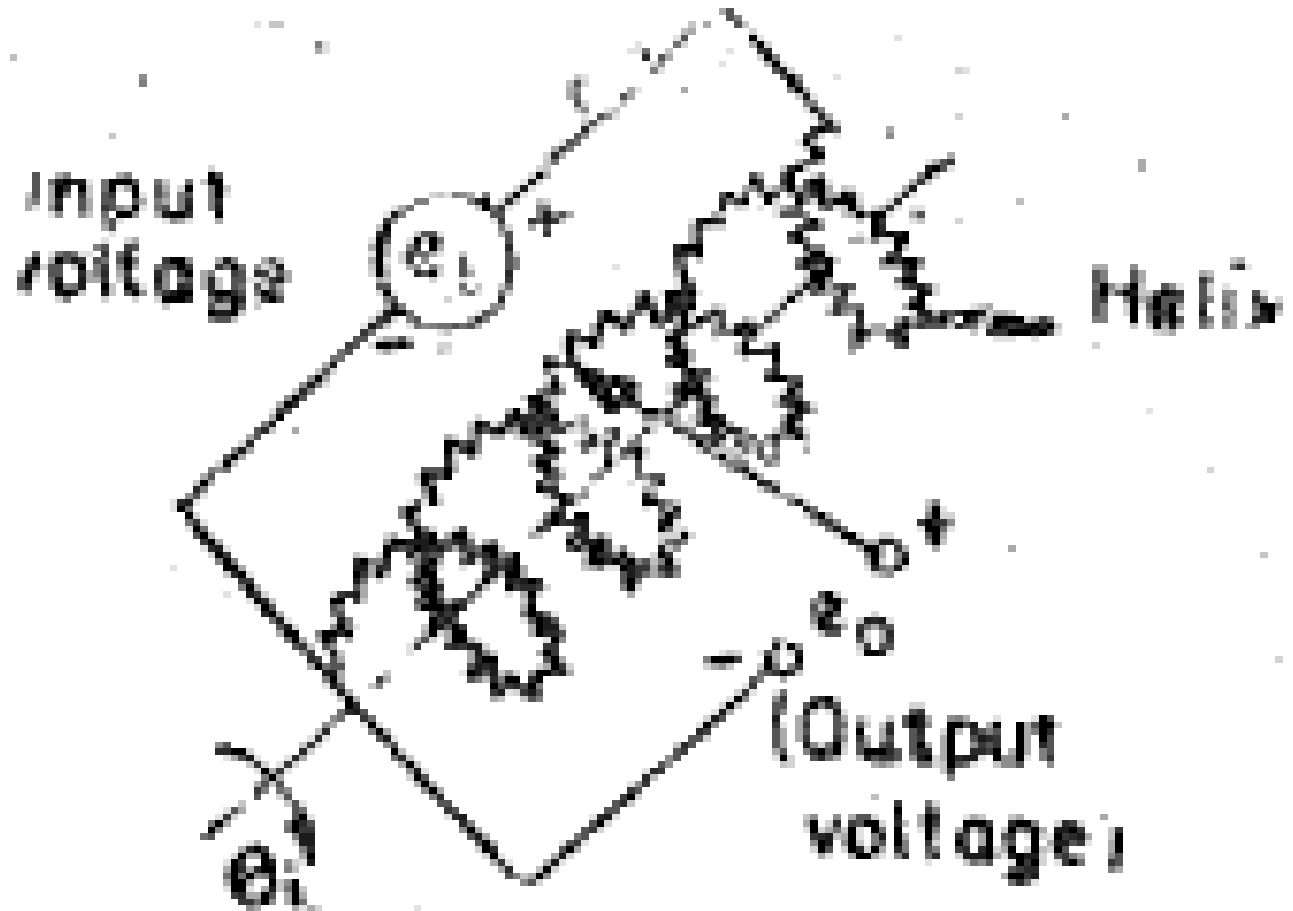

(c) Helipot (rotational)

Wire wound potentiometers

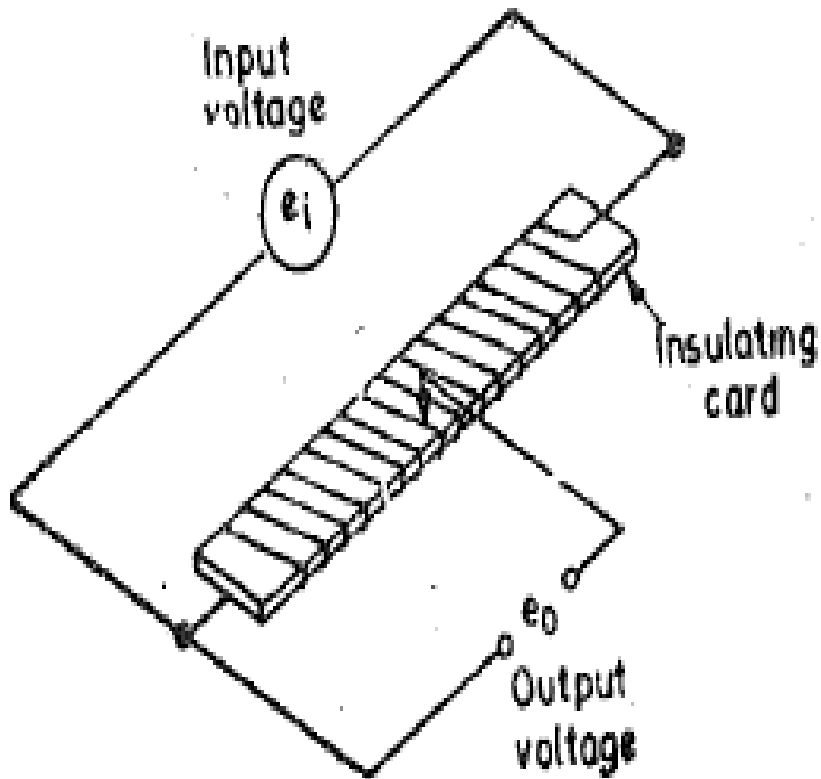

(a) Linear potentiometer.

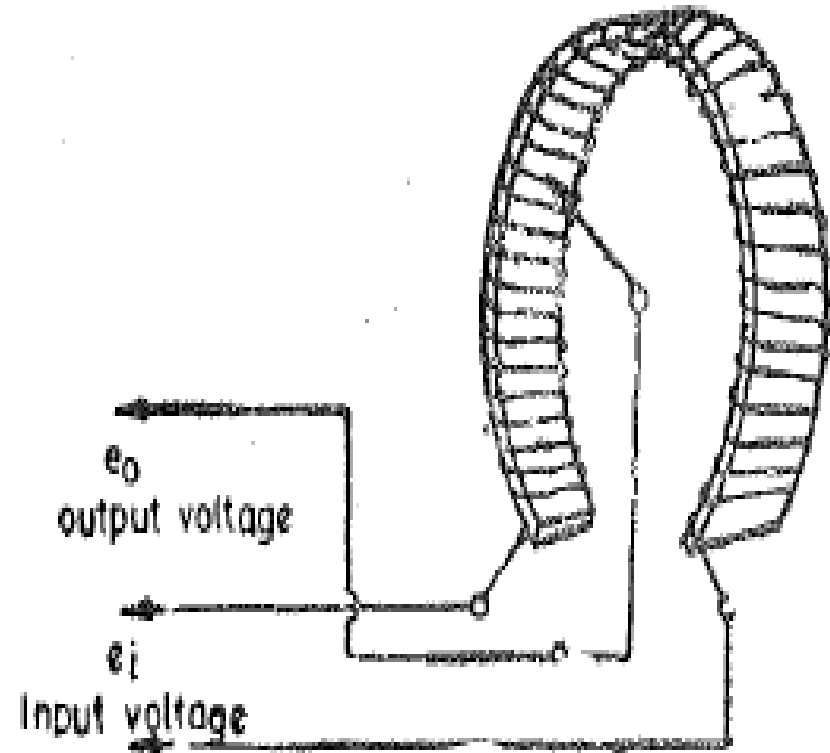

(b) Circular potentiometer.

- If wire wound type of construction is adopted, the variation of resistance is not a linear continuous change but is in small steps as the sliding contact (wiper) moves from one turn to another.

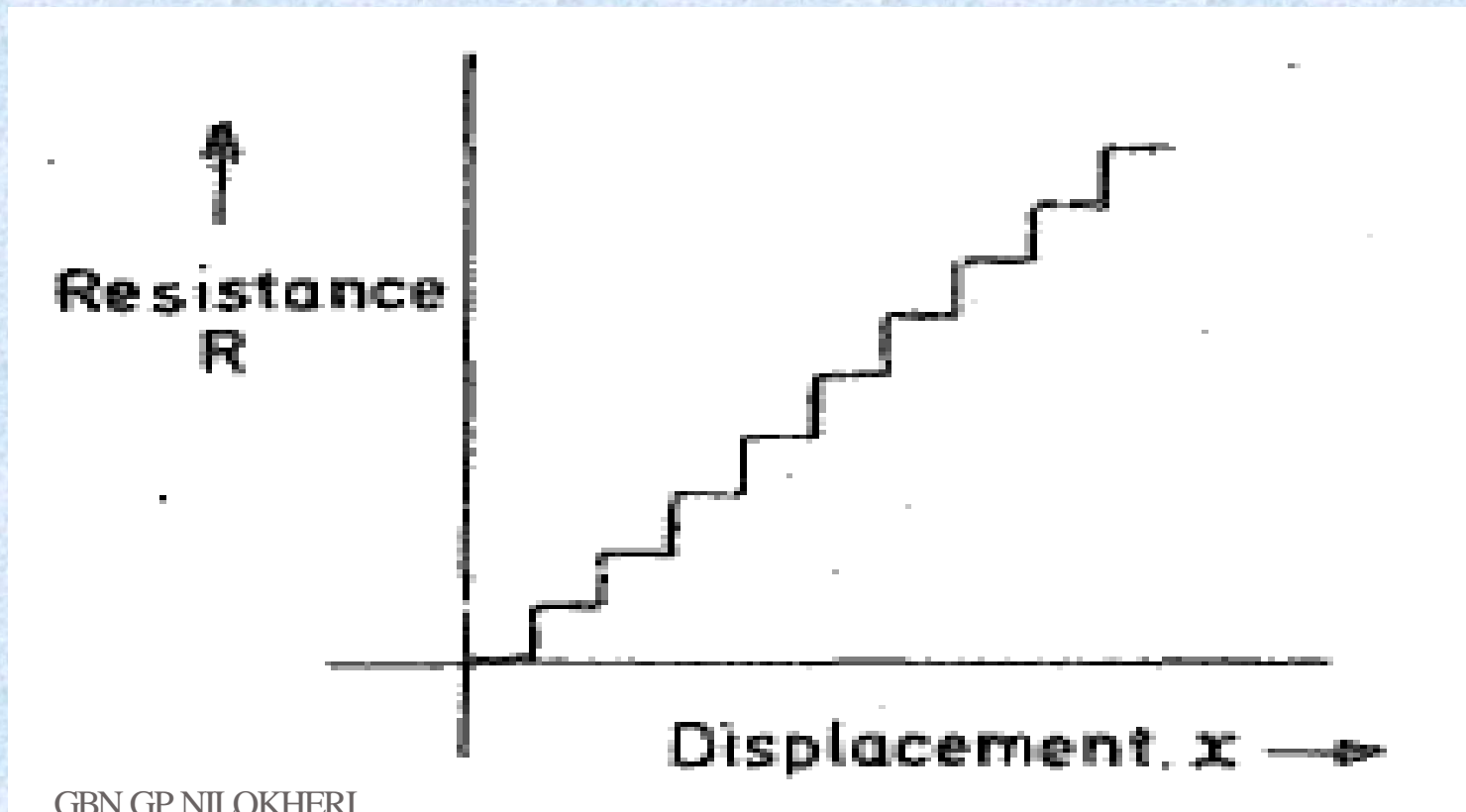

Advantages

1. They are inexpensive.
2. They are simple to operate and are very useful for applications where the requirements are not particularly severe.
3. They are very useful for measurement of large amplitudes of displacement.
4. Their electrical efficiency is very high and they provide sufficient output to permit control operations without further amplification.
5. It should be understood that while the frequency response of wire wound potentiometers is limited, the other types of potentiometers are free from this problem.
6. In wire wound potentiometers the resolution is limited while in Cermet and metal film potentiometers, the resolution is infinite.

Disadvantages

1. The chief disadvantage of using a linear potentiometer is that they require a large force to move their sliding contacts (wipers).
2. The other problems with sliding contacts are that they can be contaminated, can wear out, become misaligned and generate noise. So the life of the transducer is limited. However, recent developments have produced a roller contact wiper which, it is claimed, increases the life of the transducer by 40 times.

Variable Inductance Type Transducers

- The variable inductance type of transducers work, generally upon one of the following three principles :
 - (i) Variation of self-inductance,
 - (ii) Variation of mutual inductance and
 - (iii) Production of eddy current.

Inductive Transducers Working on Principle of Variation of Self Inductance

The self inductance of a coil $L = N^2/R$ henry.

where N = number of turns, and R = reluctance of the magnetic circuit

The reluctance of the magnetic circuit is $R = l/\mu A$.

\therefore Inductance $L = N^2 \mu(A/l) = N^2 \mu G$

where μ = effective permeability of the medium in and around the coil,

$G = A/l$ = geometric form factor, A = area of cross-section of magnetic path ; m^2 ,

l = length of magnetic path ; m

- The variation in inductance may be caused by change in number of turns, variation in geometric configuration or by change in permeability of magnetic material or magnetic circuit.

self-inductance is changed on account of change of number of turns.

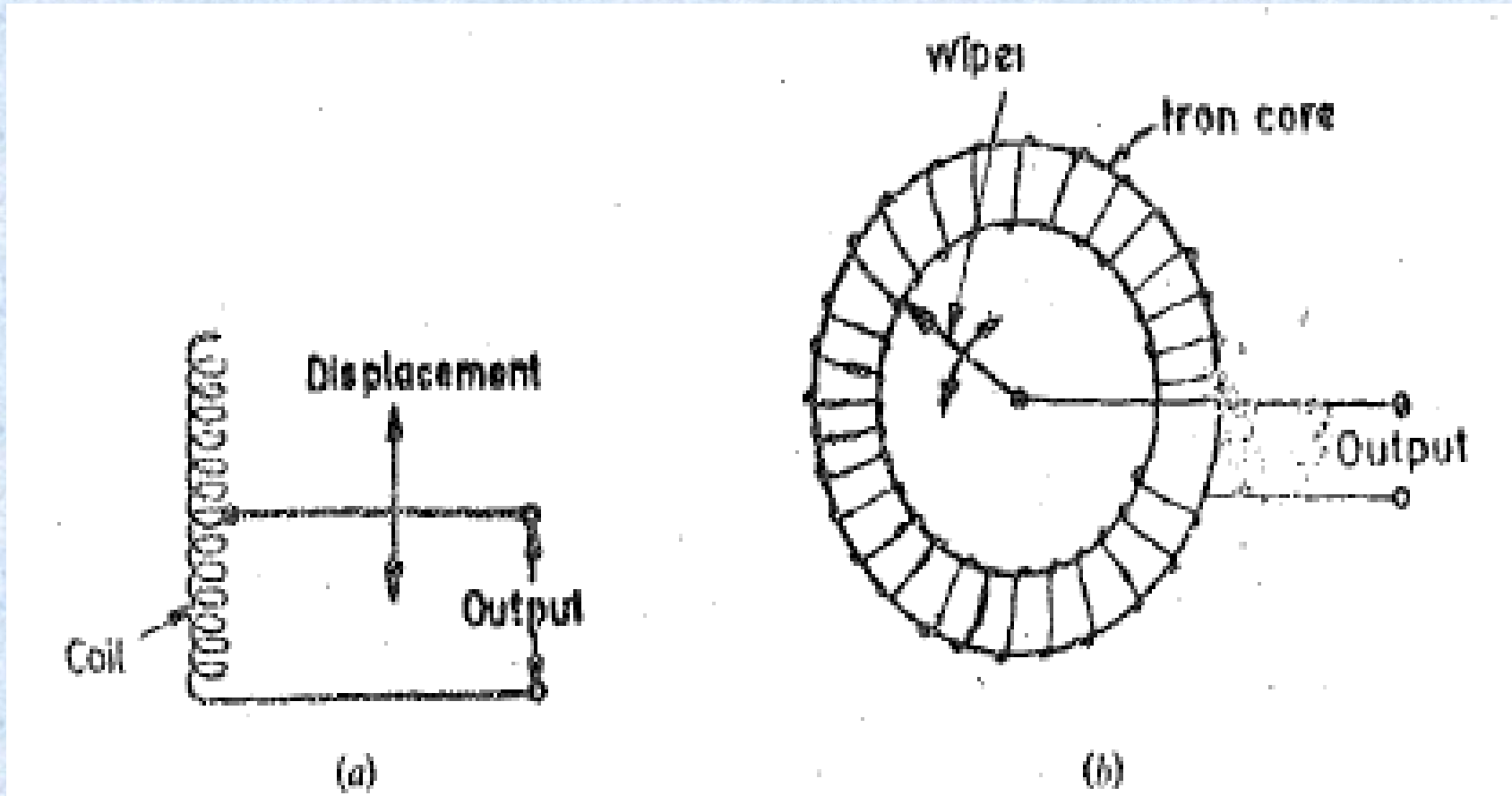

Measurement of displacement using the effect of change of geometric configuration for change in self-inductance

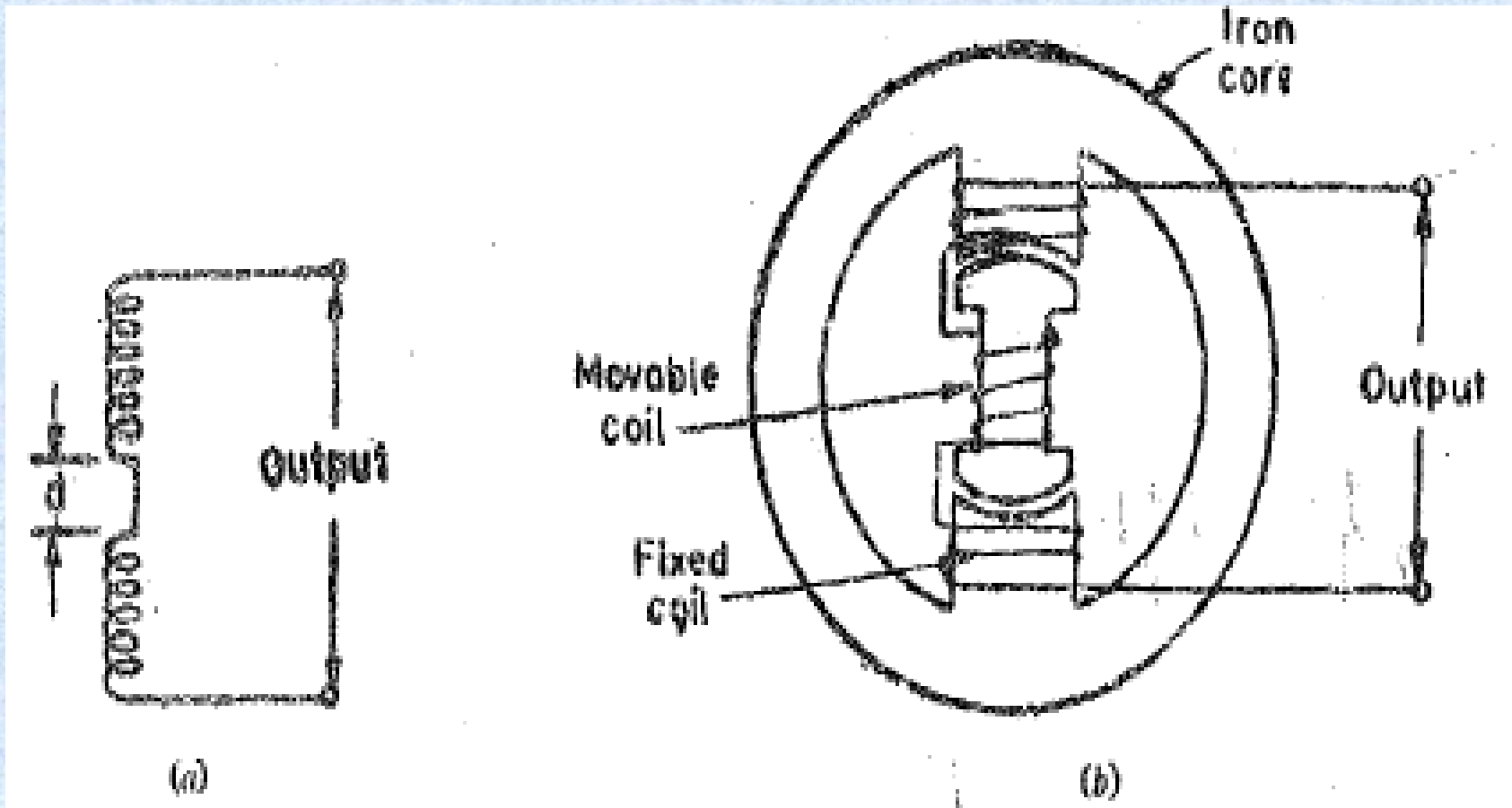

Inductive transducer for measurement of displacement using the effect of change of inductance due to change in permeability.

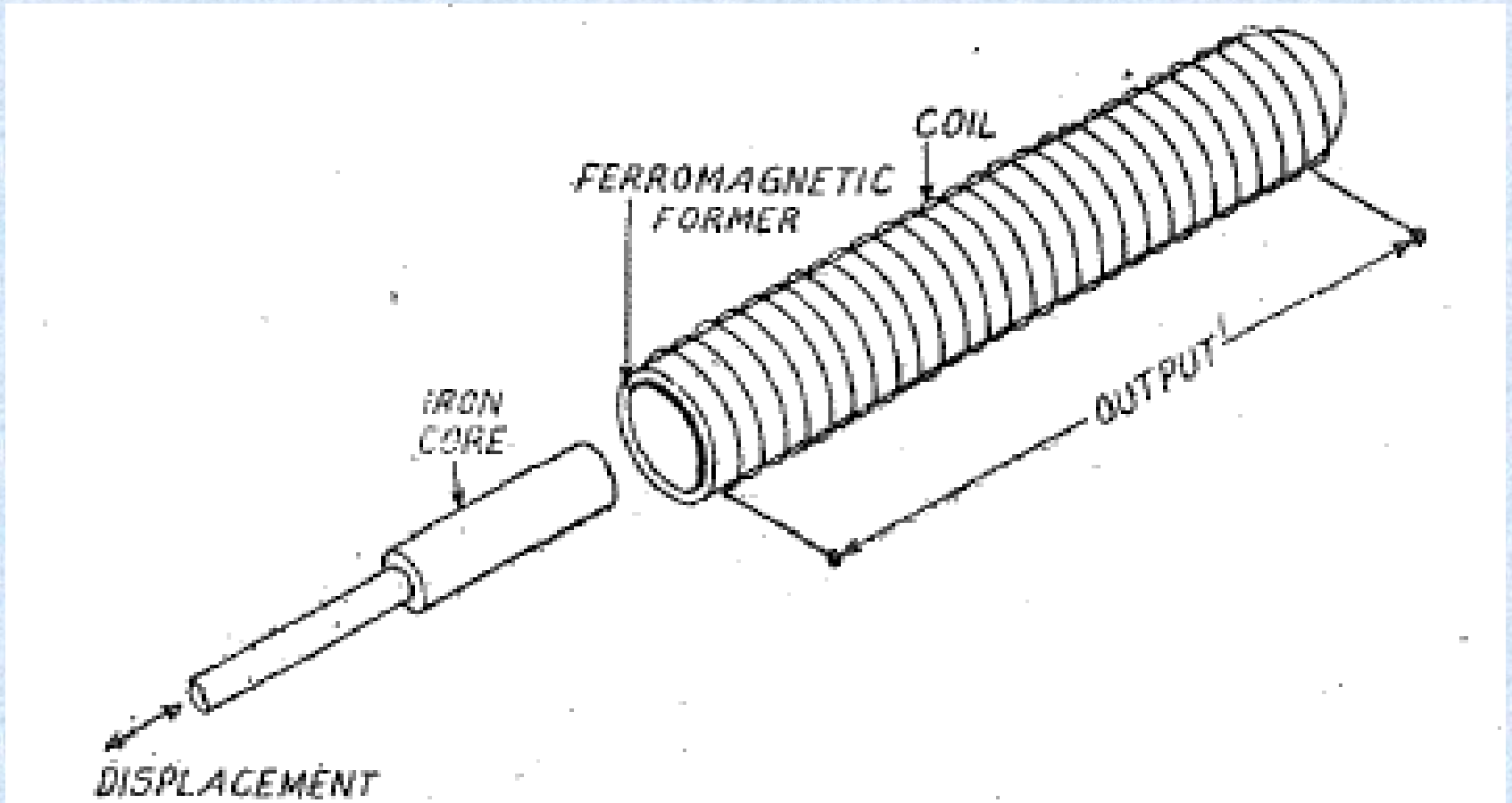

Principle of Variation of Mutual inductance

- The mutual inductance between the coils can be varied by variation of self inductances or the co-efficient of coupling.
- The self-inductance of such an arrangement varies between L_1+L_2-2M to L_1+L_2+2M

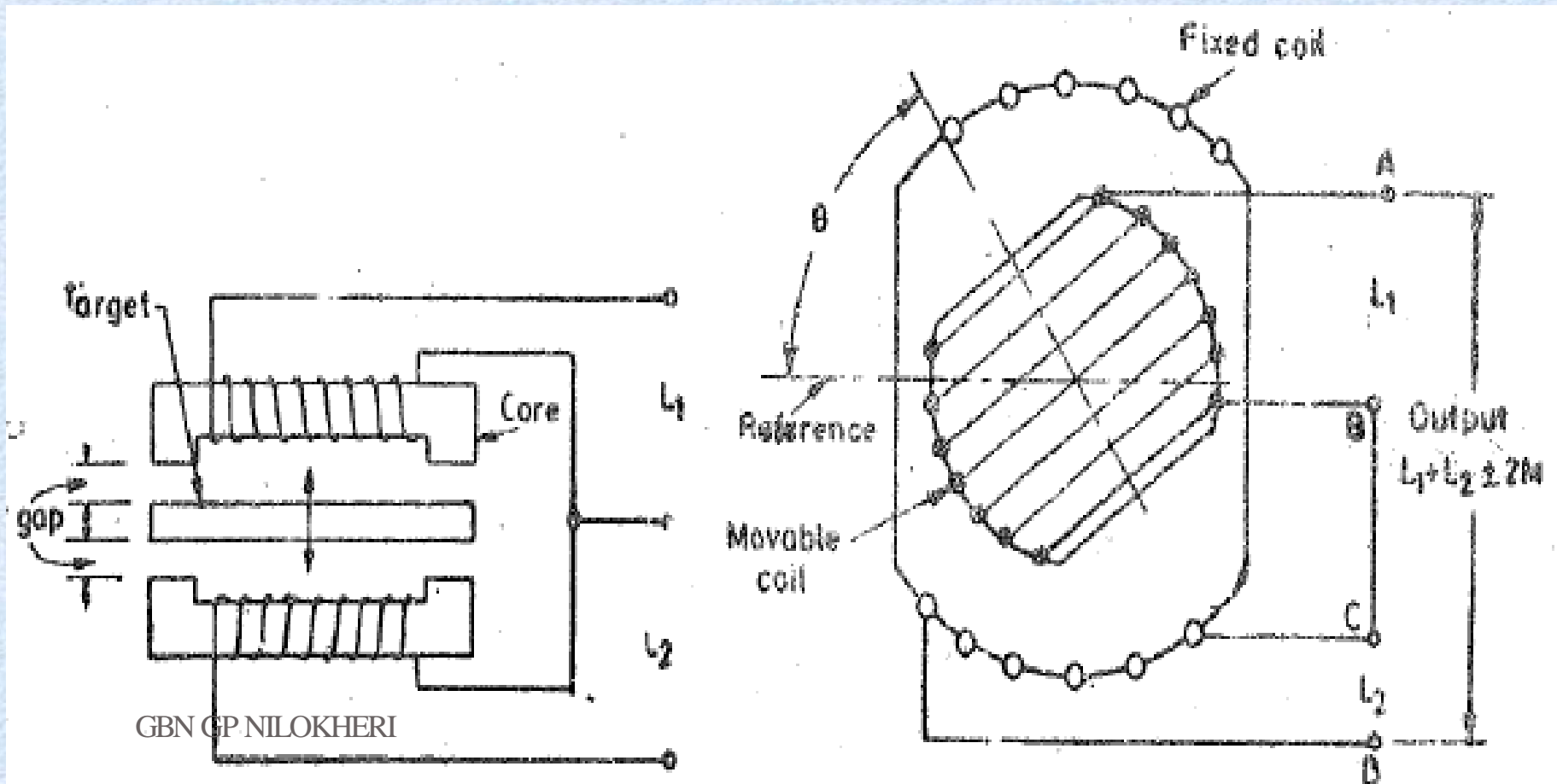

Principle of Production of Eddy Currents

- If a conducting plate is placed near a coil carrying alternating current, eddy currents are produced in the conducting plate. The conducting plate acts as a short circuited secondary of a transformer. The eddy currents flowing in the plate produce a magnetic field of their own which acts against the magnetic field produced by the coil. This results in reduction of flux and thus the inductance of the coil is reduced. The nearer is the plate to the coil, the higher are the eddy currents and thus higher is the reduction in the inductance of the coil. Thus the inductance of the coil alters with variation of distance between the plate and the coil.

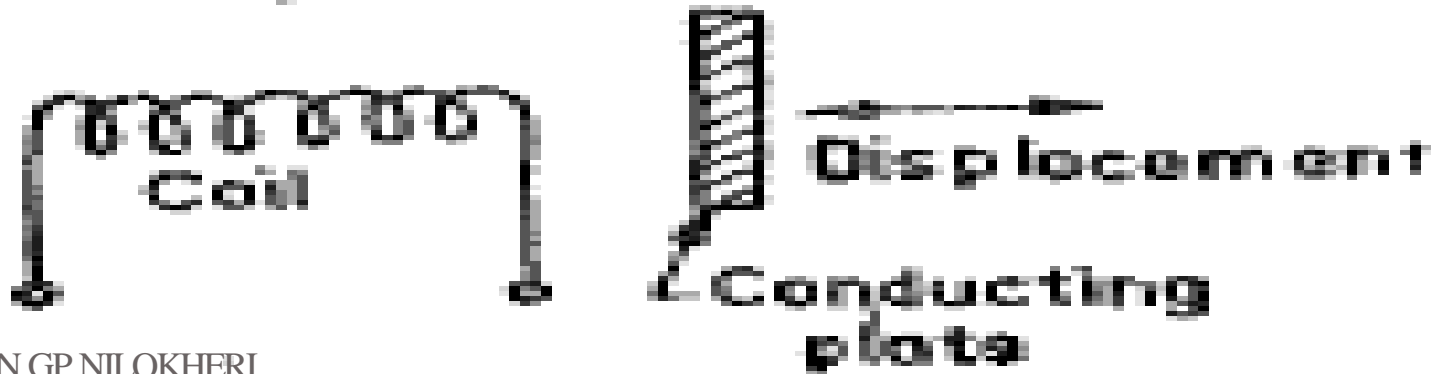

Capacitive Transducers

- The principle of operation of capacitive transducers is based upon the familiar equation for capacitance of a parallel plate capacitor.
- Where Capacitance $C = \epsilon A/d$
- A-overlapping area of plates ; m²,
- d=distance between two plates ; m,
- ϵ = permittivity (dielectric constant); F/m.

- The capacitive transducer work on the principle of change of capacitance which may be caused by :

- (i) change in overlapping area A ,

- (ii) change in the distance d between the plates,

And

- (iii) change in dielectric constant.

change in overlapping area A

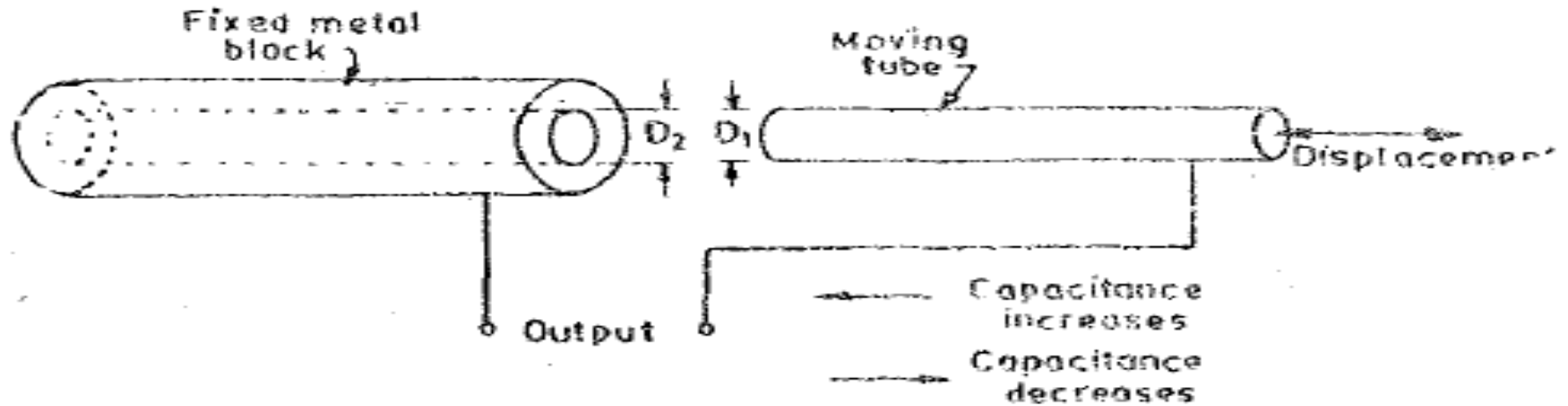

(a)

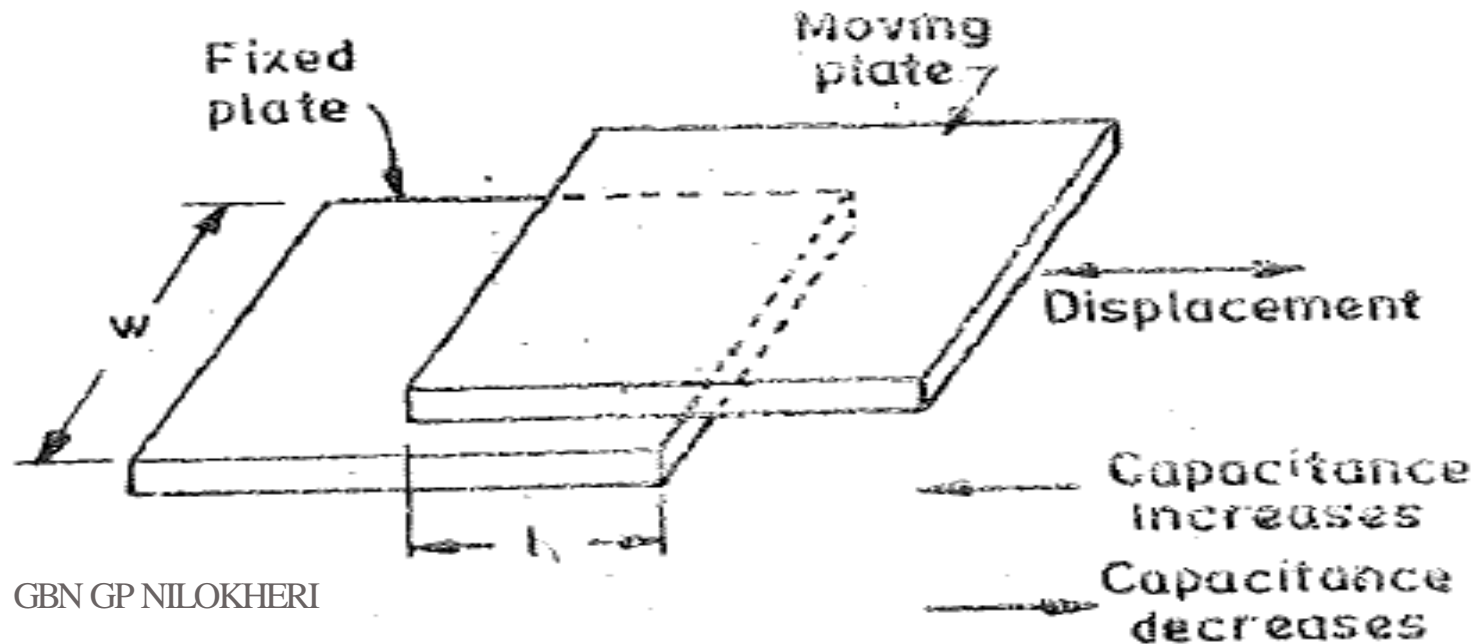

$C = \epsilon A/d = \epsilon w l/d$ F; The sensitivity is constant as

$$\text{Sensitivity } S = \frac{\partial C}{\partial l} = \epsilon \frac{w}{d} \text{ F/m}$$

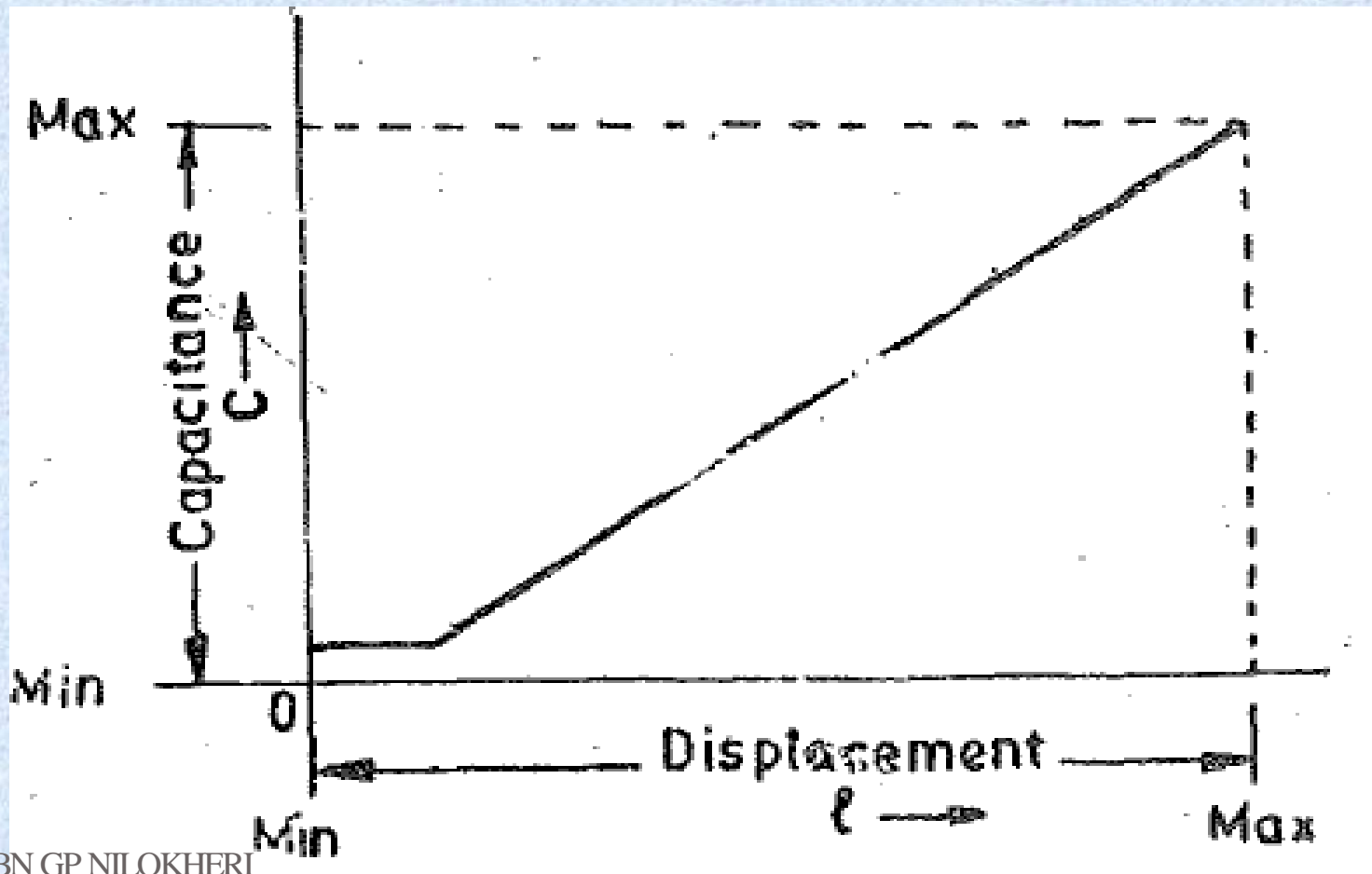

Capacitive transducer for measurement of angular displacement

Capacitance at angle θ is

$$C = \frac{\epsilon r^2}{2d} \theta$$

where θ = angular displacement in radian.

Sensitivity

$$S = \frac{\partial C}{\partial \theta} = \frac{\epsilon r^2}{2d}$$

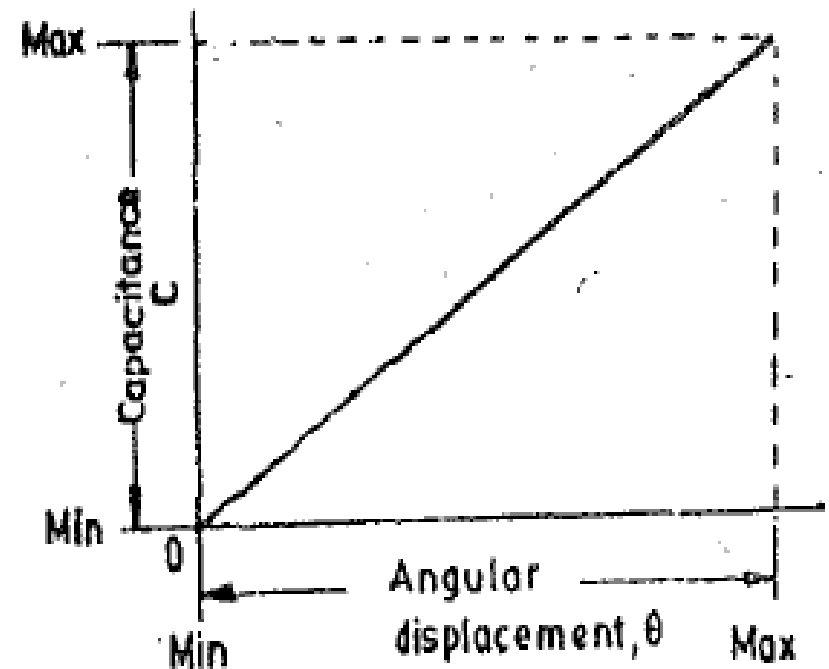
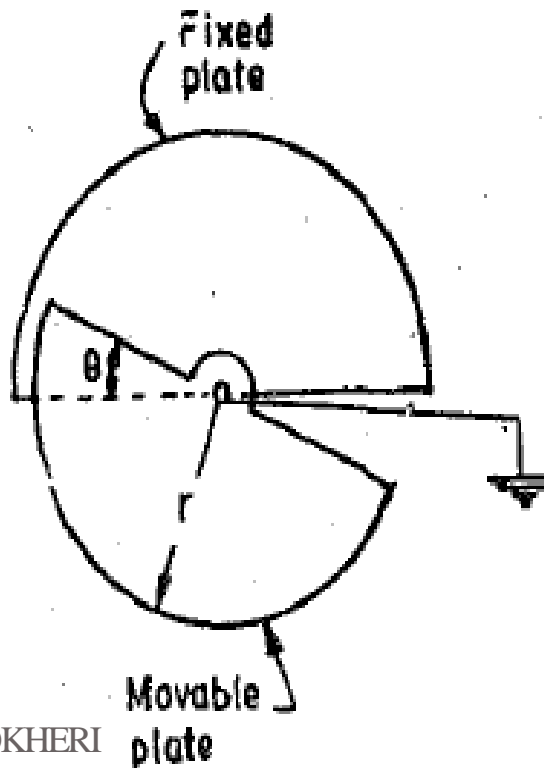

Transducers Using Change in Distance Between Plates

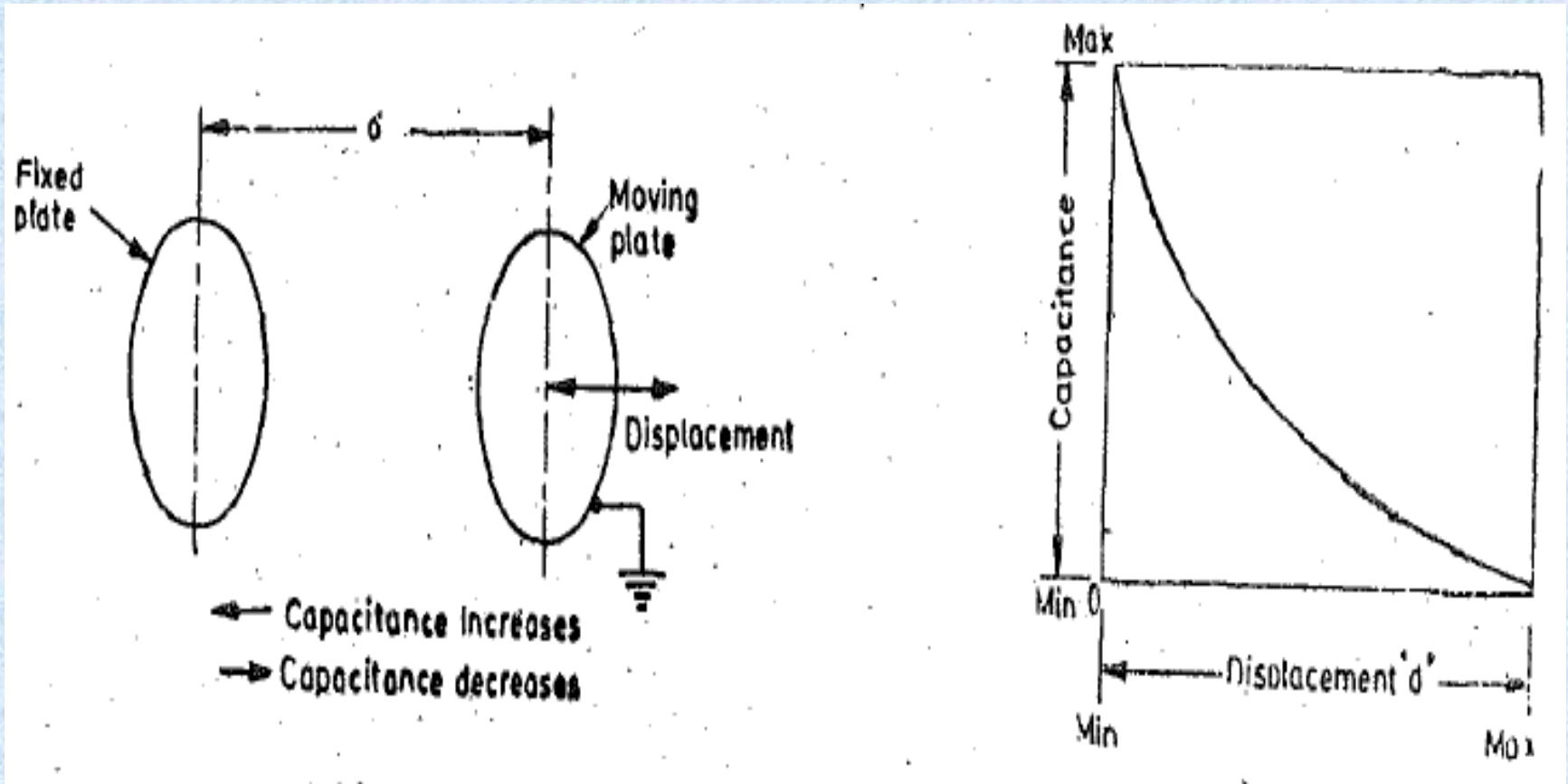

Sensitivity

$$S = \frac{\partial C}{\partial d} = - \frac{\epsilon A}{d^2}$$

The displacement when applied to the cantilever type spring plate moves it towards the second plate decreasing the distance. This increases the capacitance of the capacitor.

- It is clear that the capacitance of air dielectric capacitor does not vary linearly with change in distance between the plates, and therefore, this arrangement is fundamentally non-linear.
- However, linearity can be closely approximated by keeping the change in the distance small or by having a medium of high dielectric constant in the space between the two plates.

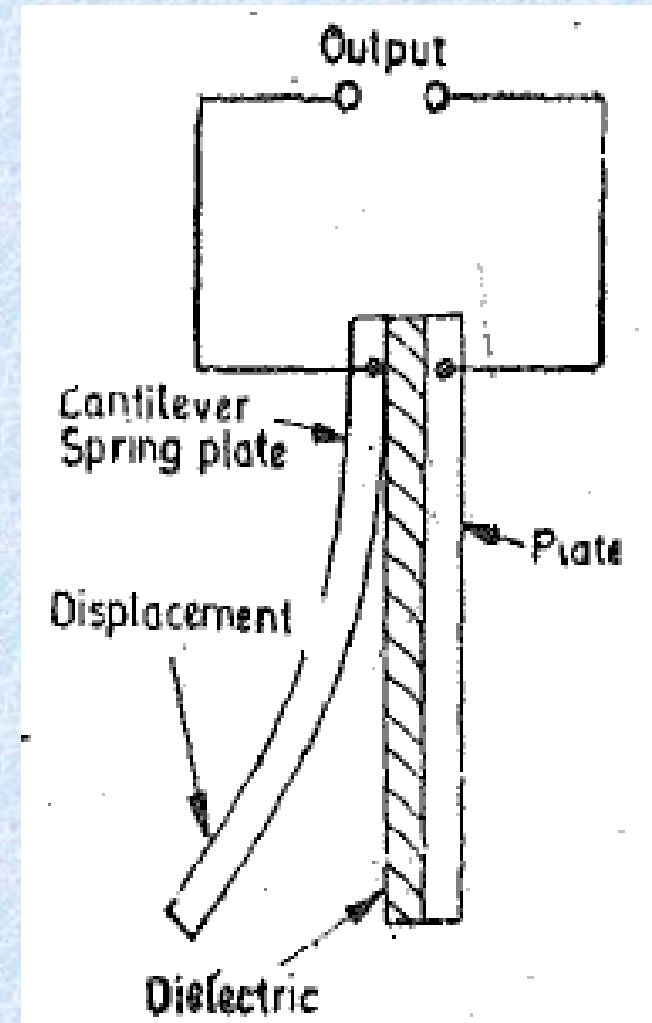

Variation of Dielectric Constant for Measurement of Displacement

$$\text{Initial capacitance of transducer} = C = \epsilon_0 \frac{wl_1}{d} + \epsilon_0 \epsilon_r \frac{wl_2}{d} = \epsilon_0 \frac{w}{d} [l_1 + \epsilon_r l_2]$$

Let the dielectric be moved through a distance x in the direction indicated. The capacitance changes from C to $C + \Delta C$.

$$\begin{aligned} \therefore C + \Delta C &= \epsilon_0 \frac{w}{d} (l_1 - x) + \epsilon_0 \epsilon_r \frac{w}{d} (l_2 + x) = \epsilon_0 \frac{w}{d} [l_1 - x + \epsilon_r (l_2 + x)] \\ &= \epsilon_0 \frac{w}{d} [l_1 + \epsilon_r l_2 + x(\epsilon_r - 1)] = C + \epsilon_0 \frac{wx}{d} (\epsilon_r - 1) \end{aligned}$$

$$\text{Change in capacitance } \Delta C = \epsilon_0 \frac{wx}{d} (\epsilon_r - 1)$$

Hence the change in capacitance is proportional to displacement.

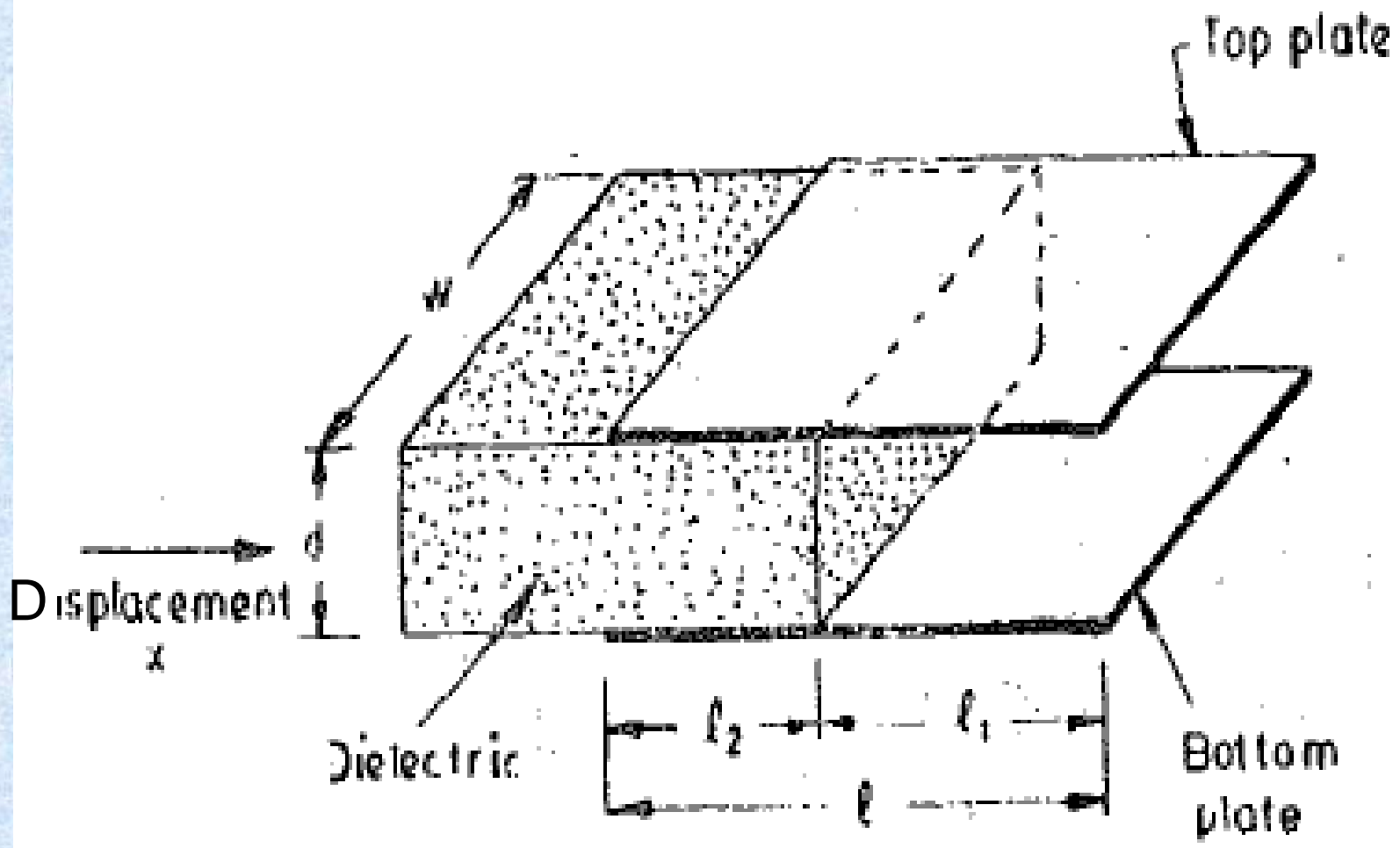

Capacitive transducer for measurement of level of a non-conducting liquid.

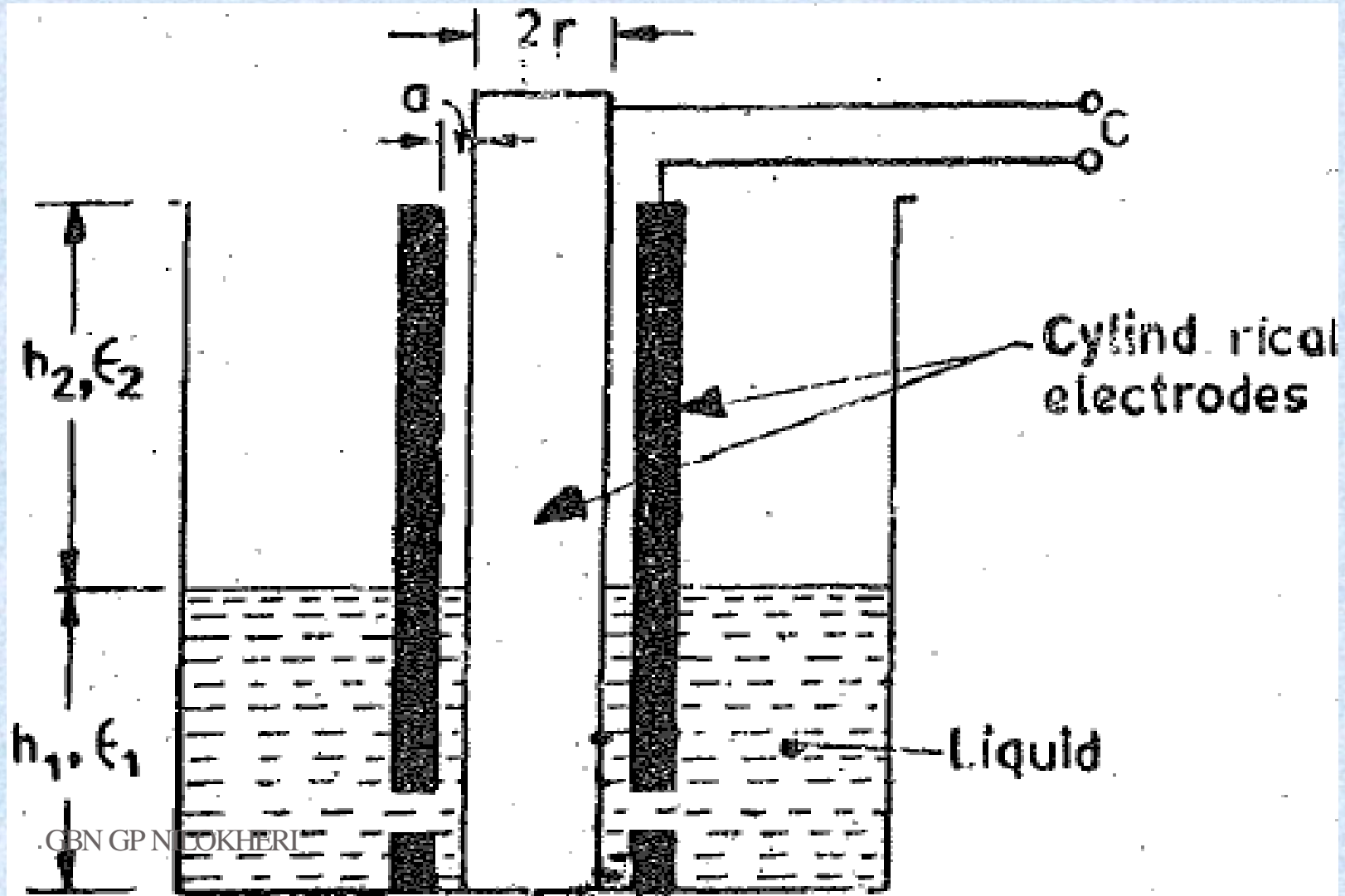

Advantages of Capacitive Transducers

1. They require extremely small forces to operate them and hence are very useful for use in small systems.
2. They are extremely sensitive.
3. They have a good frequency response. This response is as high as 50 kHz and hence they are very useful for dynamic studies.
4. They have a high input impedance and therefore the loading effects are minimum.
5. *A resolution of the order of 2.5×10^{-3} mm can be obtained with these transducers.*
6. The capacitive transducers can be used for applications where stray magnetic fields render the inductive transducers useless.
7. The force requirements of capacitive transducers is very small and therefore they require small power to operate them.

Disadvantages of Capacitive Transducers

1. The metallic parts of the capacitive transducers must be insulated from each other. In order to reduce the effects of stray capacitances, the frames must be earthed.
2. The capacitive transducers show non-linear behaviour many a times on account of edge effects. Therefore guard rings must be used to eliminate this effect. Guard rings are also a must in order to eliminate the effect of stray electric fields, especially when the transducers have a low value of capacitance of the order of pF.
3. The output impedance of capacitive transducers tends to be high on account of their small capacitance value. This leads to loading effects.
4. The capacitance of a capacitive transducer may be changed on account of presence of extraneous matter like dust particles and moisture.
5. The capacitive transducers are temperature sensitive and therefore any change in temperature adversely affects their performance.

Piezoelectric Transducers

- When a piece of a quartz crystal is subjected to force, a voltage is induced across its opposite faces. This effect is known as piezoelectric effect.
- Thus, mechanical input produces electrical output. Such materials are called as piezoelectric materials. The piezoelectric transducers are active transducers.
- The applied force/pressure causes change in physical dimensions of the crystal piece.
- The effect is reversible i.e. on application of voltage across the opposite faces, a change in physical dimensions is observed. Thus, electrical input produces mechanical output.

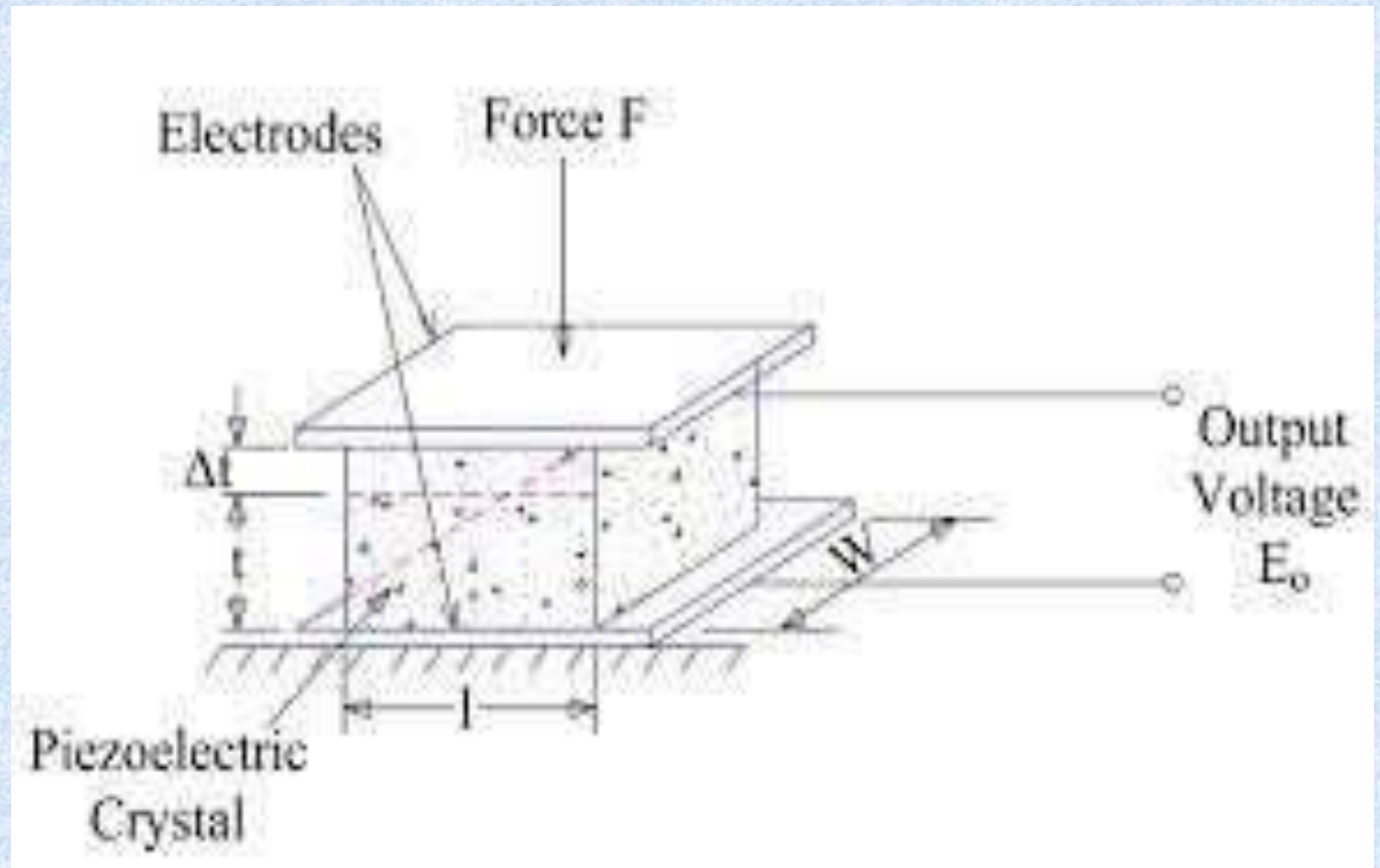

- The mechanical input- electrical output transducers are used in measurement of dynamic pressure, force, shock, vibration motion. It is also used in spark ignition engines, electrostatic dust filters.
- The electrical input- mechanical output transducers are used in industrial non-destructive testing equipments, ultrasonic flow meters, micro motion actuators testing vibration shakers.
- The voltage produced because of application of pressure/ force is given by the expression

$$E_o = \frac{Q}{C_p} = \frac{dF}{\epsilon_r \epsilon_0 A/t} = \frac{d}{\epsilon_r \epsilon_0} tP$$

- Where $\frac{d}{\epsilon_r \epsilon_0}$ is Crystal voltage sensitivity

Principle of operation

- The way a piezoelectric material is cut defines one of its three main operational modes:
 - i. Transverse
 - ii. Longitudinal
 - iii. Shear.

Transverse effect

- A force applied along a neutral axis (y) displaces charges along the (x) direction, perpendicular to the line of force. The amount of charge (Q_x) depends on the geometrical dimensions of the respective piezoelectric element. When dimensions a, b, d apply,
- $Q_x = d_{xy}F_y b/a$,
where a is the dimension in line with the neutral axis, b is in line with the charge generating axis and d is the corresponding piezoelectric coefficient.

Longitudinal effect

- The amount of charge displaced is strictly proportional to the applied force and independent of the piezoelectric element size and shape. Putting several elements mechanically in series and electrically in parallel is the only way to increase the charge output. The resulting charge is
- $Q_x = d_{xx} F_x n$,
- where d_{xx} is the piezoelectric coefficient for a charge in x-direction released by forces applied along x-direction. F_x is the applied Force in x-direction and n corresponds to the number of stacked elements.

Shear effect[

- The charge produced is exactly proportional to the applied force and is generated at a right angle to the force. The charge is independent of the element size and shape. For n elements mechanically in series and electrically in parallel the charge is
- $Q_x = 2d_{xx} F_x n$.
- In contrast to the longitudinal and shear effects, the transverse effect make it possible to fine-tune sensitivity on the applied force and element dimension.

Electromagnetic Transducers

Electromagnetic transducers are used for the measurement of linear velocity. These transducers utilise the voltage produced in a coil on account of change in flux linkages resulting from change in reluctance. Fig. 2.13 shows the basic diagram of an electromagnetic transducer.

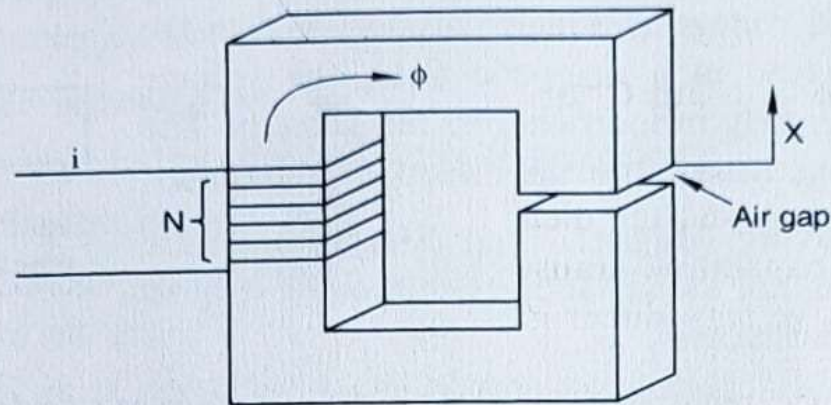

Fig. 2.13. Electromagnetic Transducer.

In general, the output voltage from a coil is given by

$$e_o = \frac{d\phi}{dt} = \frac{N}{R} \frac{di}{dt} - \frac{Ni}{R^2} \frac{dR}{dt}$$

In case, i is constant,

$$e_o = \frac{Ni}{R^2} \cdot \frac{dR}{dt}$$

Hence output voltage,

$$e_o \propto \frac{dR}{dt} \quad \dots(v)$$

Equation (v) is derived on the basis of the following explanation.

If the average value of reluctance R is higher greater than the variations in R , the quantity Ni/R^2 is almost constant. Therefore, the rate of change of flux is directly proportional to the rate of change of reluctance. The change in flux produces an output voltage which is directly proportional to the rate of change of reluctance. The reluctance varies directly as the length of air gap and therefore the output voltage is directly proportional to the rate of change of air gap and to the velocity. Therefore, this type of transducer is velocity sensitive.

■ 2.8. CLASSIFICATION OF ELECTROMAGNETIC TRANSDUCERS

The electromagnetic transducers are classified into two categories :

- (i) Moving magnet type electromagnetic transducers
- (ii) Moving coil type velocity transducers.

■ 2.8.1. Moving Magnet Type Electromagnetic Transducers

A typical moving magnet type transducer is as shown in Fig. 2.14. The sensing element is a rod rigidly coupled to the device whose velocity is being measured. This rod is a permanent magnet.

There is a coil surrounding the permanent magnet due to which the motion of the magnet induces a voltage in the coil and the amplitude of the voltage is directly proportional to the velocity. For a coil placed in a magnetic field, the voltage induced in the coil is directly proportional to the velocity. The polarity of output voltage determines the direction of motion.

Advantages of Moving Magnet Type Electromagnetic Transducers : Following are the advantages of moving magnet type electromagnetic transducers :

- (i) The maintenance requirements of these transducers are negligible, because there are no mechanical surfaces or contacts.
- (ii) The output voltage is linearly proportional to velocity.
- (iii) These transducers can be used as event markers which are robust and inexpensive to manufacture.

Disadvantages of Moving Magnet Type Electromagnetic Transducers : Following are the disadvantages of moving magnet type electromagnetic transducers :

- (i) Stray magnetic fields cause noise and hence affect the performance of these transducers.
- (ii) The frequency response is limited and is stated.
- (iii) These are not useful for the measurement of vibrations.

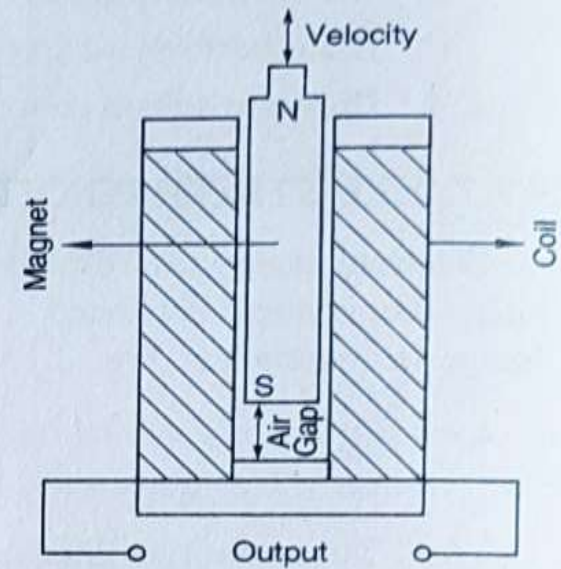

Fig. 2.14. Moving magnet type electromagnetic transducer.

Moving Coil Type Velocity Transducers

The moving coil type velocity transducer as shown in Fig. 2.15 operates essentially through the action of a coil moving in a magnetic field. A voltage is generated in the coil which is proportional to the velocity of the coil.

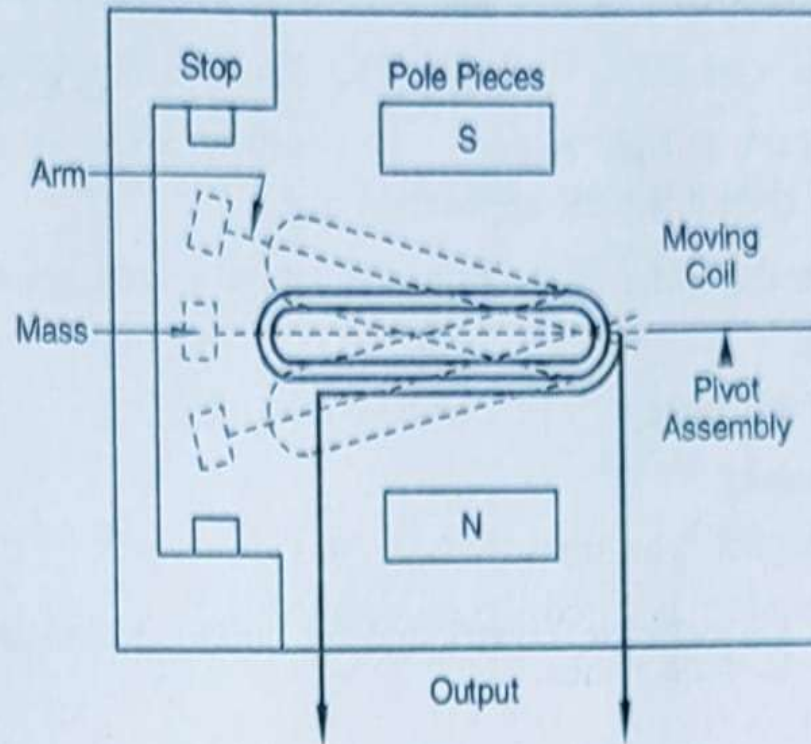

Fig. 2.15. Moving coil type velocity transducer.

Advantages of Moving Magnet Type Velocity Transducers : Following are the advantages of moving magnet type velocity transducers :

- (i) Its maintenance is negligible.
- (ii) The output voltage is linearly proportional to velocity.
- (iii) Cost of manufacture is less.
- (iv) It is more satisfactory arrangement as the system now forms a closed magnetic circuit with a constant air gap.
- (v) The whole device is contained in an antimagnetic case which reduces the effects of stray magnetic fields.

Disadvantages of Moving Magnet Type Velocity Transducers : Following are the disadvantages of moving magnet type velocity transducers :

- (i) The frequency response is poor.
- (ii) Though antimagnetic case reduces the effects of stray magnetic fields but still remaining stray magnetic fields effects.

STRAIN GAUGE

DEFINITION

- A strain gauge is an example of passive transducer that converts a mechanical displacement into a change of resistance.
- A strain gauge is a thin wafer like device that can be attached to a variety of materials to measure applied strain.

WORKING

- The strain gauge is connected into a Wheatstone Bridge circuit. The change in resistance is proportional to applied strain and is measured with Wheatstone bridge.

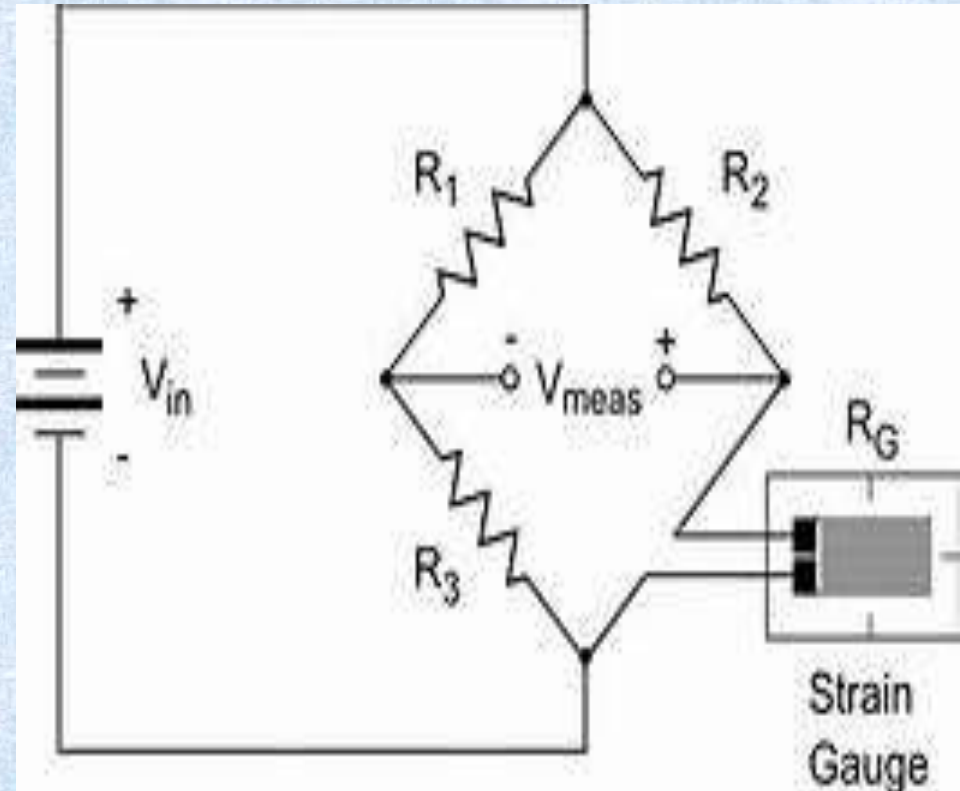

WORKING

- The sensitivity of a strain gauge is described in terms of a characteristic called the gauge factor, defined as unit change in resistance per unit change in length or

- $G = \frac{\Delta R/R}{\Delta L/L}$

- Gauge factor is related to Poisson's ratio ν by,
- $G = 1 + 2\nu$.

Calculating Gauge Factor in Strain Gauge : Let we have a metallic wire of length L as given below :

A tensile stress is applied to the wire which produces a +ve strain on it.

Let A is the X-sectional area of wire before stress is applied

Let D is the diameter of wire before stress is applied

Let $\Delta L =$ Change in Length

$\Delta A =$ Change in Area (Reduction in area due to +ve strain)

$\Delta D =$ Change in Diameter

The resistance of the strain gauge wire is given as

$$R_G = \rho \frac{L}{A} \Omega \quad \dots(1)$$

where $\rho =$ resistivity of wire is ohm-m

$L =$ Length of wire is meters

$A =$ Cross-sectional area in wire in m^2

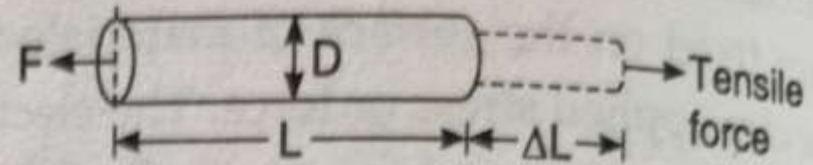

Fig. 3.6

Now to find the change in resistance ΔR , differentiate equation (1) w.r.t. stress, s , we get :

$$\frac{\partial R_G}{\partial s} = \frac{\rho}{A} \frac{\partial L}{\partial s} - \frac{\rho L}{A^2} \frac{\partial A}{\partial s} + \frac{L}{A} \frac{\partial \rho}{\partial s} \quad \dots(2)$$

Dividing above equation by $R = \frac{\rho L}{A}$, we get

$$\frac{1}{R_G} \frac{\partial}{\partial s} R_G = \frac{1}{L} \frac{\partial L}{\partial s} - \frac{1}{A} \frac{\partial A}{\partial s} + \frac{1}{\rho} \frac{\partial \rho}{\partial s} \quad \dots(3)$$

$$\Rightarrow \frac{1}{R} \frac{\partial}{\partial s} R_G = \frac{1}{L} \frac{\partial L}{\partial s} - \frac{1}{A} \frac{\partial}{\partial s} \left[\frac{\pi}{4} D^2 \right] + \frac{1}{\rho} \frac{\partial \rho}{\partial s}$$

$$\Rightarrow \frac{1}{R_G} \frac{\partial}{\partial s} R_G = \frac{1}{L} \frac{\partial L}{\partial s} - \frac{1}{\frac{\pi}{4} D^2} \times 2 \times \frac{\pi D}{4} \frac{\partial D}{\partial s} + \frac{1}{\rho} \frac{\partial \rho}{\partial s}$$

$$\Rightarrow \frac{1}{R_G} \frac{\partial}{\partial s} R_G = \frac{1}{L} \frac{\partial L}{\partial s} - \frac{2}{D} \frac{\partial D}{\partial s} + \frac{1}{\rho} \frac{\partial \rho}{\partial s} \quad \dots(4)$$

We know that Poisson's ratio is defined as ratio of lateral strain to longitudinal strain

$$i.e., \quad v = - \frac{\partial D/D}{\partial L/L} \quad \dots(5)$$

$$\Rightarrow - \frac{\partial D}{D} = v \frac{dL}{L} \quad \dots(6)$$

Putting this value in eq. (4), we get

$$\frac{1}{R_G} \frac{\partial}{\partial s} R_G = \frac{1}{L} \frac{\partial L}{\partial s} + \frac{2v}{L} \frac{\partial L}{\partial s} + \frac{1}{\rho} \frac{\partial \rho}{\partial s} \quad \dots(7)$$

For small variation, the above eq. (7) can be written as

$$\frac{\Delta R}{R_G} = \frac{\Delta L}{L} + 2v \frac{\Delta L}{L} + \frac{\Delta \rho}{\rho}$$

Dividing both sides by $\frac{\Delta L}{L}$, we get

$$\frac{\frac{\Delta R}{R_G}}{\frac{\Delta L}{L}} = 1 + 2v + \frac{\frac{\Delta \rho}{\rho}}{\frac{\Delta L}{L}}$$

$$\Rightarrow \text{Gauge factor} \quad G_f = 1 + 2v + \frac{\Delta \rho / \rho}{\epsilon}$$

where $\frac{\Delta R / R_G}{\Delta L / L} = \text{Gauge Factor}$

$v = \text{Poisson's ratio}$

$$\frac{\Delta L}{L} = \epsilon \text{ (Strain)}$$

and term $\frac{\Delta \rho}{\rho}$ = called resistance change due to piezoresistive effect

Neglecting change in resistivity of a good material when strain, we get the relation of gauge factor and Poisson's ratio as

$$\boxed{G_f = 1 + 2v}$$

Also the ratio of stress and strain is called modulus of elasticity.

$$E = \frac{F/A}{\Delta L/l} = \frac{\text{Stress}}{\epsilon} = \frac{\text{Stress}}{\text{Strain}}$$

TYPES OF STRAIN GAUGES

- Unbonded metal strain gauges
- Bonded metal wire strain gauges
- Bonded metal foil strain gauges
- Vacuum deposited thin metal film strain gauges
- Sputter deposited thin metal film strain gauges
- Semiconductor strain gauges

Metallic Strain Gauge

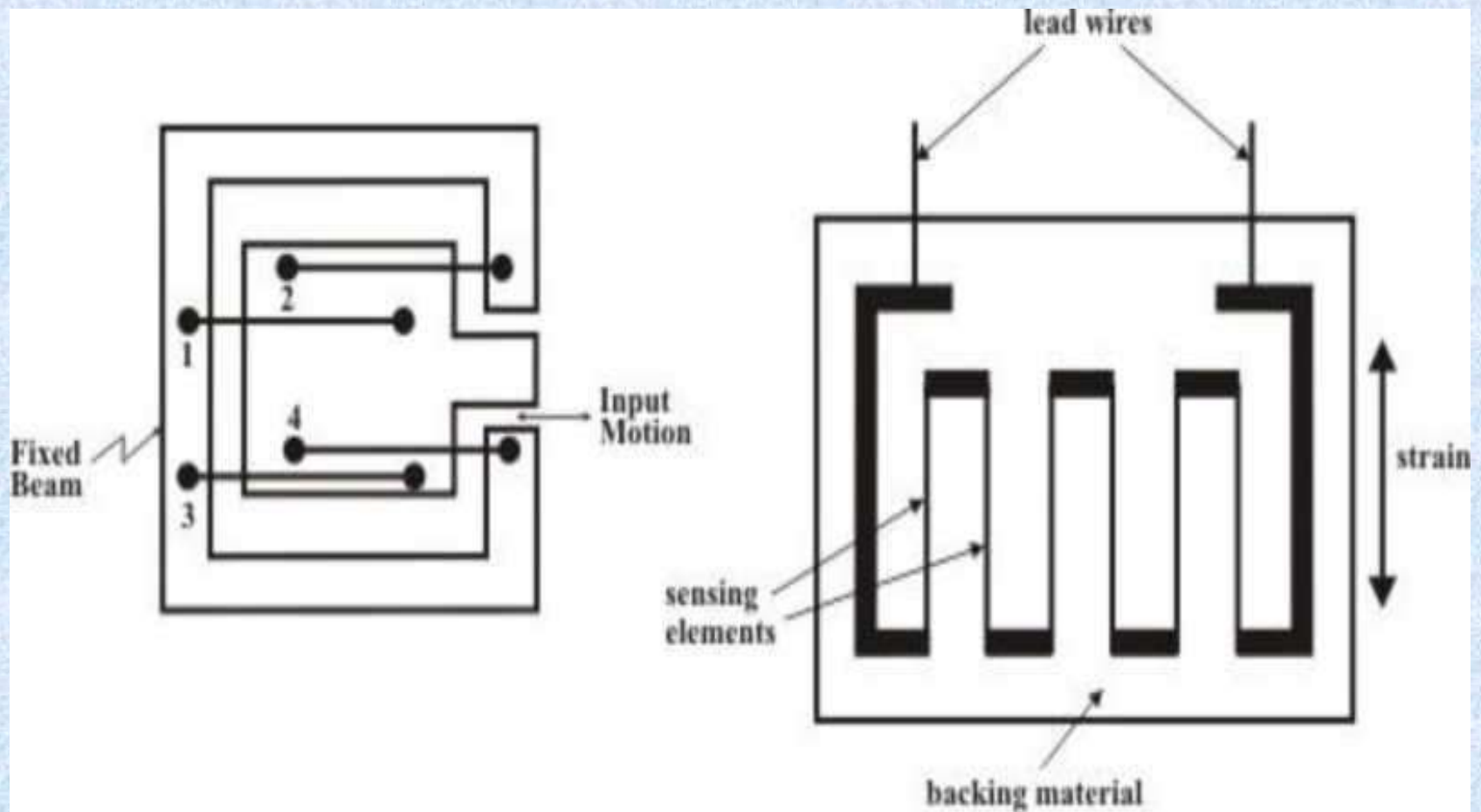
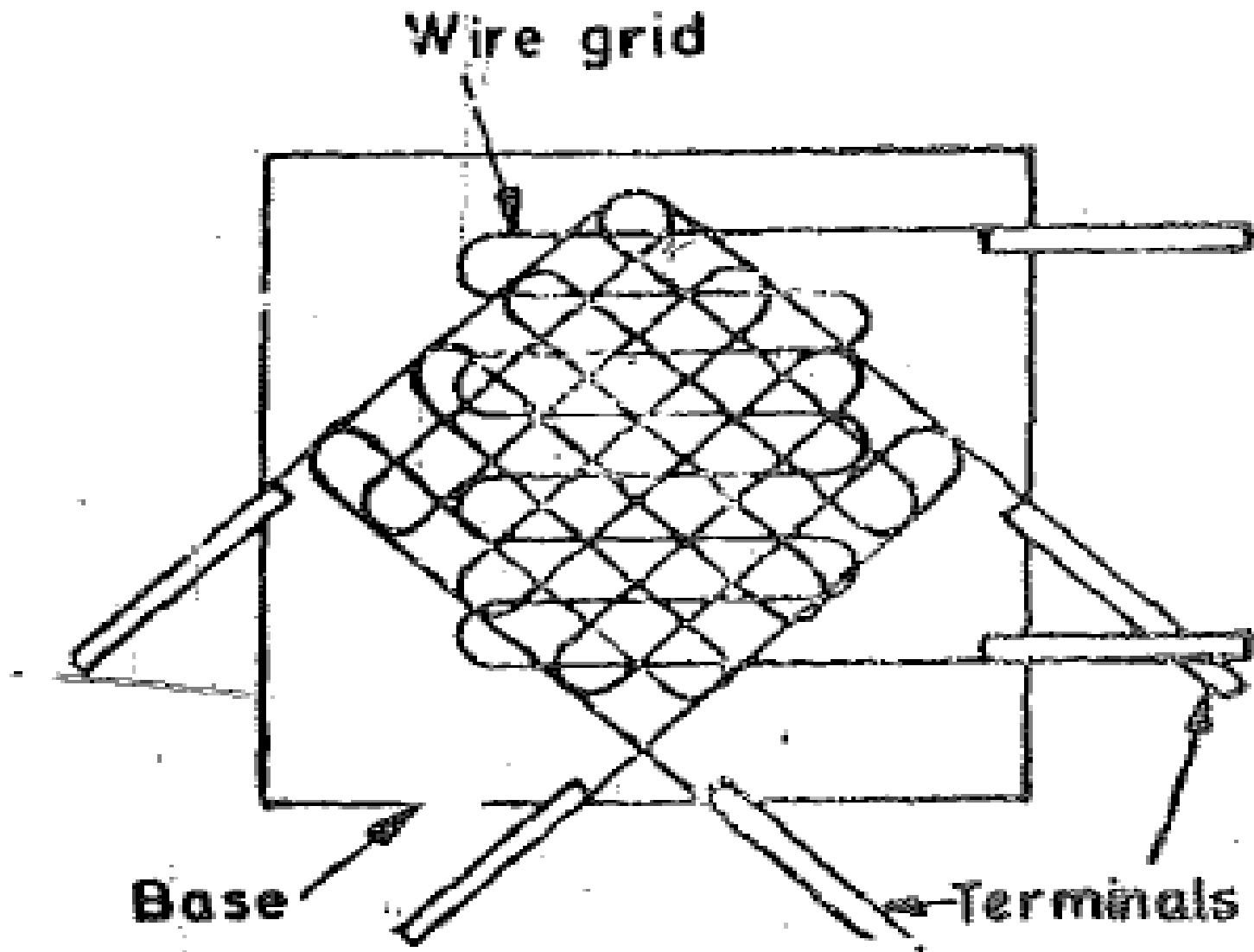

Fig. 6 (a) Unbonded metallic strain gauge, (b) bonded metal foil type strain gauge

- Most of the strain gages are metallic type. They can be of two types: *unbonded* and *bonded*. The unbonded strain gage is normally used for measuring strain (or displacement) between a fixed and a moving structure by fixing four metallic wires in such a way, so that two are in compression and two are in tension, as shown in fig. 6 (a). On the other hand, in the bonded strain gage, the element is fixed on a backing material, which is permanently fixed over a structure, whose strain has to be measured, with adhesive. Most commonly used bonded strain gages are *metal foil type*. The construction of such a strain gage is shown in fig. 6(b).

- The metal foil type strain gage is manufactured by photo-etching technique. Here the thin strips of the foil are the active elements of the strain gage, while the thick ones are for providing electrical connections. Because of large area of the thick portion, their resistance is small and they do not contribute to any change in resistance due to strain, but increase the heat dissipation area. Also it is easier to connect the lead wires with the strain gage. The strain gage in fig. 6(b) can measure strain in one direction only. But if we want to measure the strain in two or more directions at the same point, strain gage *rosette*, which is manufactured by stacking multiple strain gages in different directions, is used.



(b) Rosette.

Semi-conductor Strain Gauges.

- Semiconductor strain gauges are used where a very high gauge factor and a small envelope are required. The resistance of the semi-conductors changes with change in applied strain.
- Unlike in the case of metallic gauges where the change in resistance is mainly due to change in dimensions when strained, the semi-conductor strain gauges depend for their action upon Piezo-resistive effect i.e.
- the Change in the Value of the resistance due to Change in resistivity.
- A high gauge factor means a relatively higher change in resistance which can be easily measured with a good degree of accuracy.
- semiconducting materials such as silicon and germanium are used as resistive materials for semi-conductor strain gauges.

- The production of these gauges employs conventional semiconductor technology using semiconducting wafers or filaments which have a thickness of 0.05 mm and bonding them on a suitable insulating substrates, such as Teflon. Gold leads are generally employed for making the contacts.

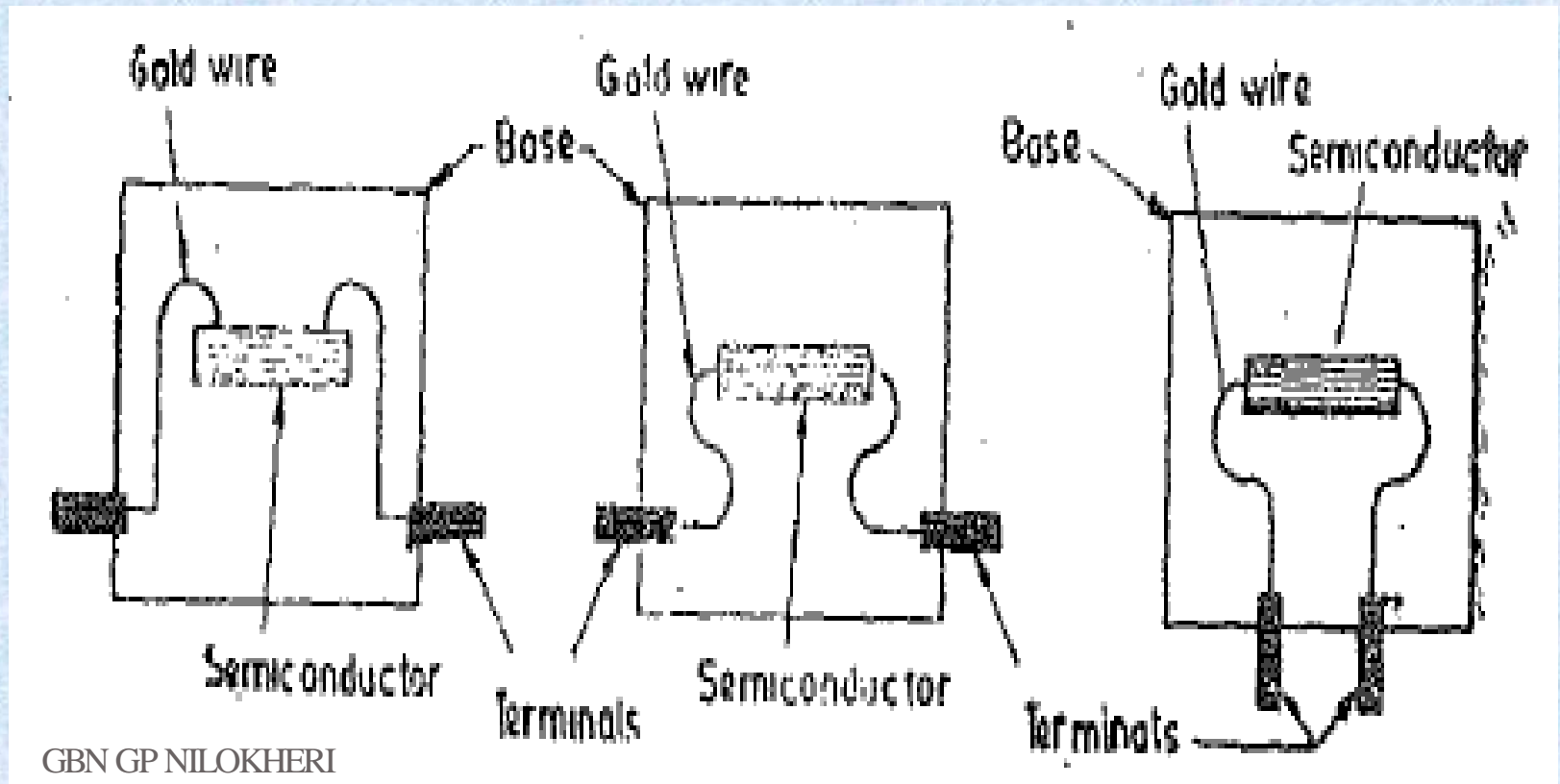

Advantages

- (i) Semi conductor strain gauges have the advantage that they have a high gauge factor of about ± 130 . This allows measurement of very small strains of the order of 0.01 micro strain.
- (ii) Hysteresis characteristics of semi-conductor strain gauges are excellent. Some units maintain it to less than 0.05%.
- (iii) Fatigue life is in excess of 10×10^6 operations and the frequency response is up to 10^{12} Hz.
- (iv) Semi-conductor strain gauges can be very small ranging in length from 0.7 to 7 mm. They are very useful for measurement of local strains.

Disadvantages

- i. The major and serious disadvantage of semiconductor strain gauges is that they are very sensitive to changes in temperature.
- ii. Linearity of the semi-conductor strain gauges is poor. The equation for the fractional change in resistance is :
- iii. $\Delta R/R = A\varepsilon + B\varepsilon^2$ where A and B are constants.
- iv. This gauge is rather non-linear at comparatively high strain levels. The gauge factor varies with strain. For example if the gauge factor is 130 at 0.2 per cent strain, then it is 112 at 0.4 per cent strain. The characteristics can be made linear by proper doping.
- v. Semi-conductor strain gauges are more expensive and difficult to attach to the object under study.

APPLICATIONS

- Residual stress and Vibration measurement, Torque measurement, Bending and deflection measurement, Compression and tension measurement, Strain measurement

**LINEAR VARIABLE
DIFFERENTIAL TRANSFORMER
(LVDT)**

CONTENTS:

- LVDT
- CONSTRUCTION
- PRINCIPLE
- OPERATION
- USES

LINEAR VARIABLE DIFFERENTIAL TRANSFORMER (LVDT)

- Linear variable-differential transformer is the most widely used Inductive transducer to translate linear motion into electrical signal.

CONSTRUCTION :

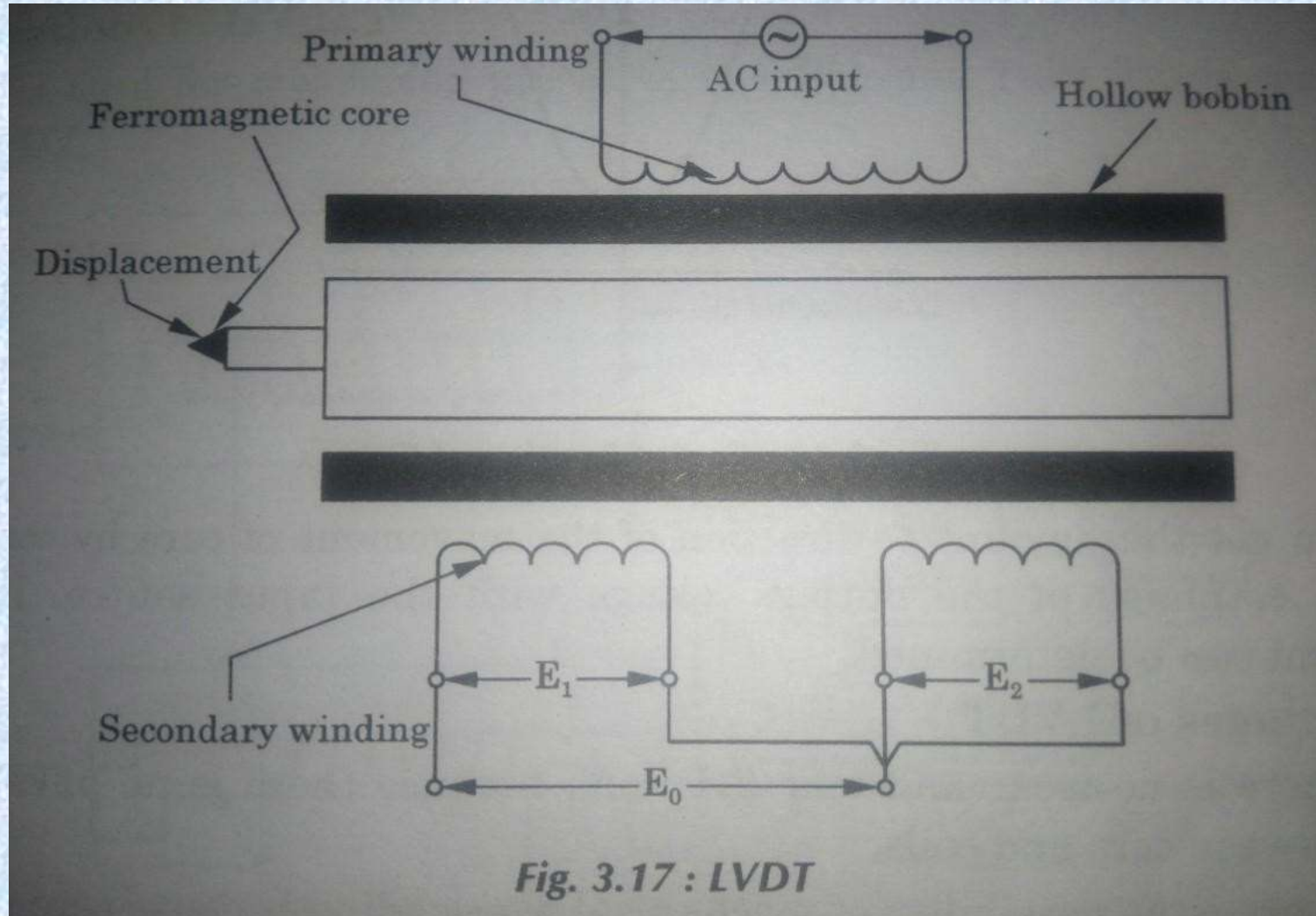

Fig. 3.17 : LVDT

- A differential transformer consists of a primary winding and two secondary windings. The windings are arranged concentrically and next to each other.
- A ferromagnetic core (armature) in the shape of a rod or cylinder is attached to the transducer sensing shaft.
- The core slides freely within the hollow portion of the bobbin.

PRINCIPLE :

- Any physical displacement of the core causes the voltage of one secondary winding to increase while simultaneously reducing the voltage in the other secondary winding.
- The difference of the two voltages appears across the output terminals of the transducers and gives a measure of the physical position of the core and hence displacement.

working:

- When the core is in the neutral or zero position and two secondary windings are equal and opposite and the net output is negligible.
- Now if the core is moved to the left of the NULL position, more flux links with winding S_1 and less with winding S_2 . Accordingly output voltage E_{s_1} of the secondary winding S_1 is more than E_{s_2} , the output voltage of secondary winding S_2 .
- The magnitude of output voltage is, thus $E_{s_1} - E_{s_2}$ and the output voltage is in phase with E_{s_1} i.e. the output voltage of secondary winding S_1 .
- Similarly, if the core is moved to the right of the null position, the flux linking with winding S_2 becomes larger than that linking with winding S_1 . This results in E_{s_2} becoming larger than E_{s_1} .
- The output voltage in this case is $E_o = E_{s_2} - E_{s_1}$ and is in phase with E_{s_2} i.e. the output voltage of secondary winding S_2 .
- By comparing the magnitude and phase of output with input source, the amount and direction of movement of core and hence displacement may be determined.

Variation output voltage with linear displacement for an LVDT.

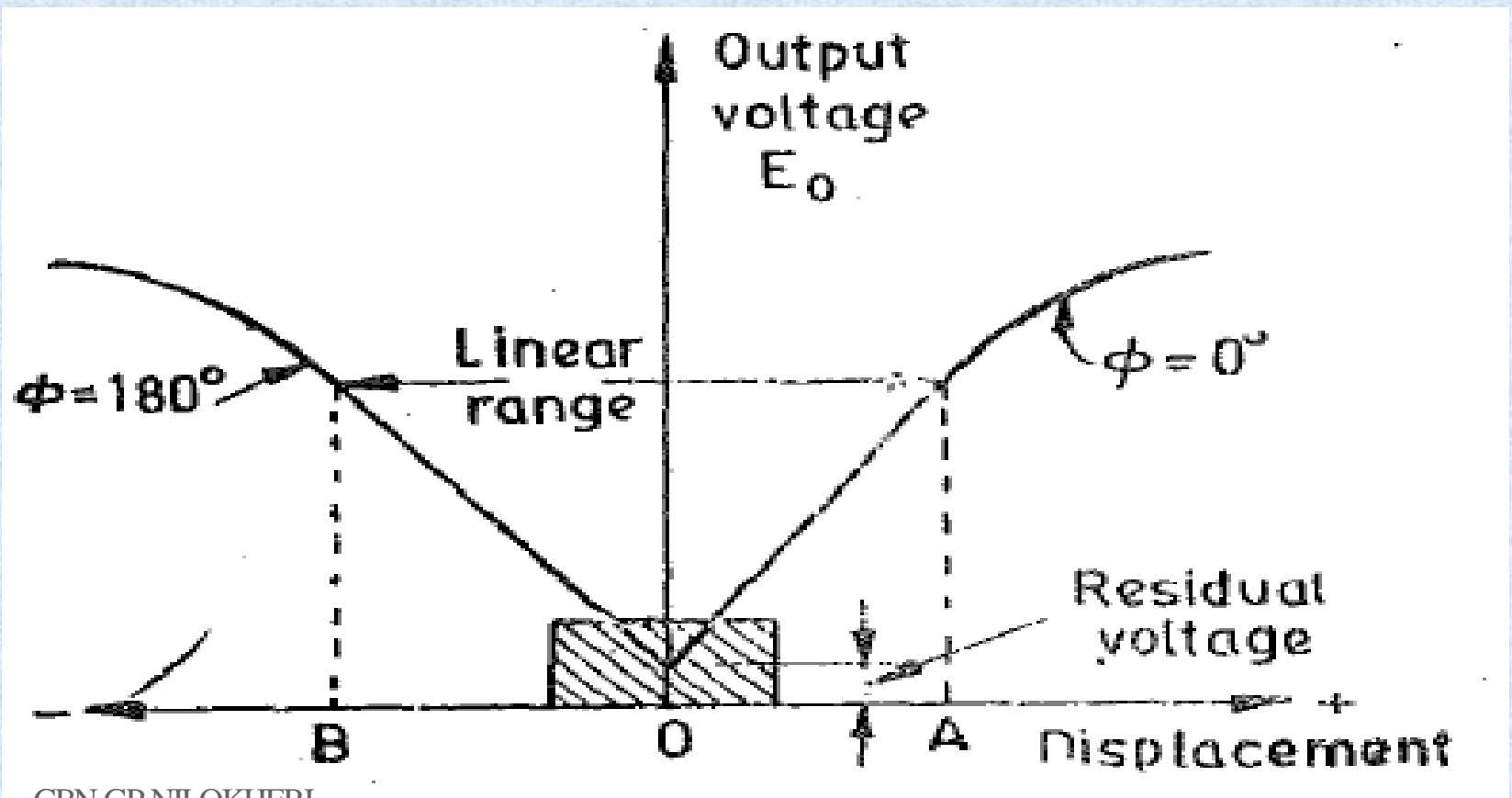

Advantages of LVDTs

- Linearity.
- Infinite resolution .
- High output.
- High sensitivity.
- Ruggedness.
- Less friction.
- Low hysteresis.
- Low power consumption

Disadvantages of LVDTs

1. Relatively large displacements are required for appreciable differential output.
2. They are sensitive to stray magnetic fields but shielding is possible. This is done by providing magnetic shields with longitudinal slots.
3. Many a times, the transducer performance is affected by vibrations.
4. The receiving instrument must be selected to operate on a.c. signals or a demodulator network must be used if a d.c. output is required.
5. The dynamic response is limited mechanically by the mass of the core and electrically by the frequency of applied voltage. The frequency of the carrier should be at least ten times the highest frequency component to be measured.
6. Temperature affects the performance of the transducer.

USES

- The LVDT can be used in all applications where displacements ranging from fraction of a mm to few cm have to be measured.
- Acting as a secondary transducer it can be used as a device to measure force, weight, pressure etc.

Torque measurement

TORQUE

It is defined as the force acting on a body which tends to produce rotation.

Mathematically ,torque is given as :

$$T = F \times D$$

Where, T = torque

F = force

D = perpendicular distance from the axis of rotation of the line of action of force

A number of devices which can be used for the measurement of torque is :

1. Strain gauge torque meter
2. Inductive torque transducer
3. Magnetostrictive transducer
4. Digital methods

1. STRAIN GAUGE TORQUE METER :-

In this method , two strain gauges are mounted on a shaft at an angle of 45° to each other .

The torque is given by the relation ;

$$T = \frac{\pi G(R^4 - r^4)}{2L} \theta \text{Nm}$$

Where, G = modulus of rigidity measured in N/m^2 .

R = outer radius of the shaft measured in m.

r = inner radius of the shaft measured in m.

L = length of the shaft measured in m.

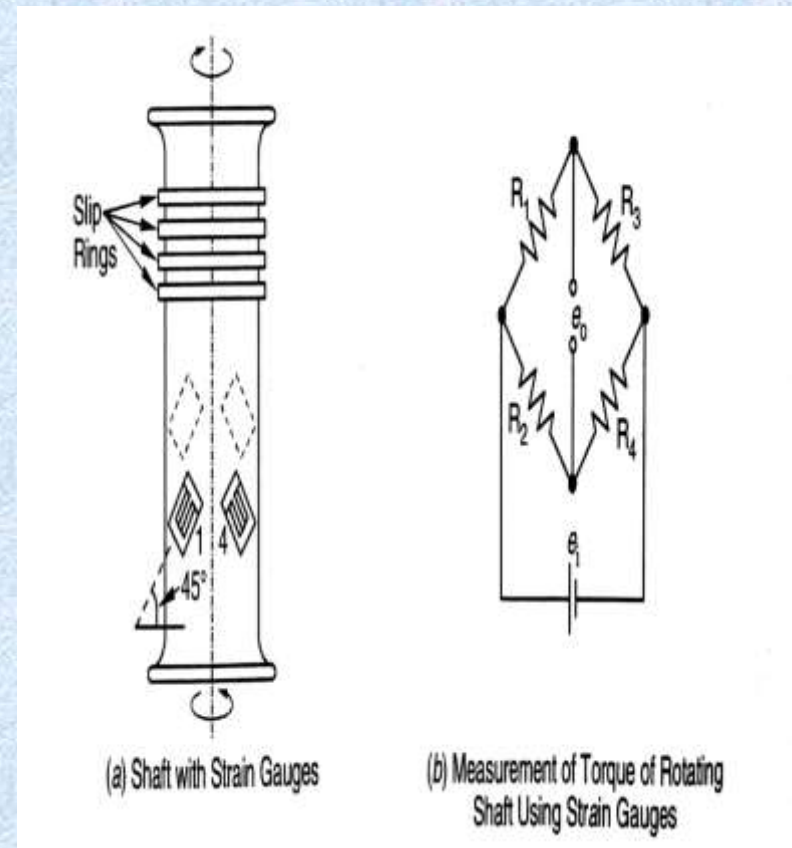

THEORY:-

A strain gauge is generally measured by electrical means, In this arrangement , two strain gauges are subjected to tensile stresses while the other two experience Compressive stresses to indicated the torque.

The gauges must be at 45 with the shaft axis. Gauge 1 and 2 must be diametrically opposite , as must gauge 3 and 4 .

ADVANTAGE :- 1. They are fully temperature compensated.
2. they give a maximum sensitivity for a given torque.

2. Inductive torque transducer

In inductive torque transducer, flange A carries a coil and flange B, an iron core. This core is move IN an OUT of the coil according to the relative displacement of the two flanges.

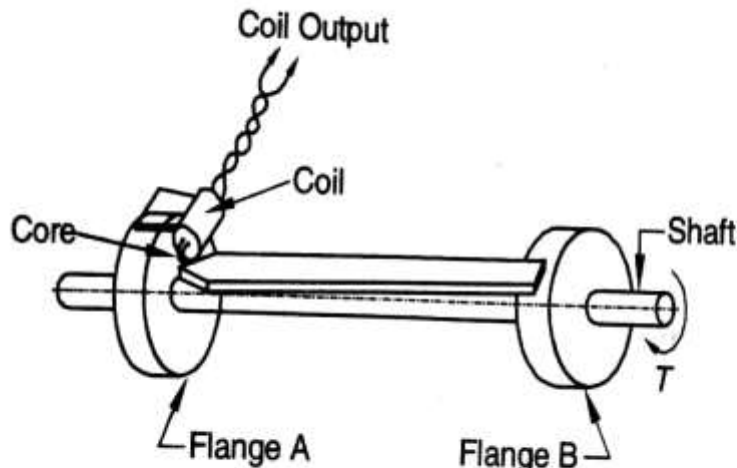

(a) Inductive Torque Transducer

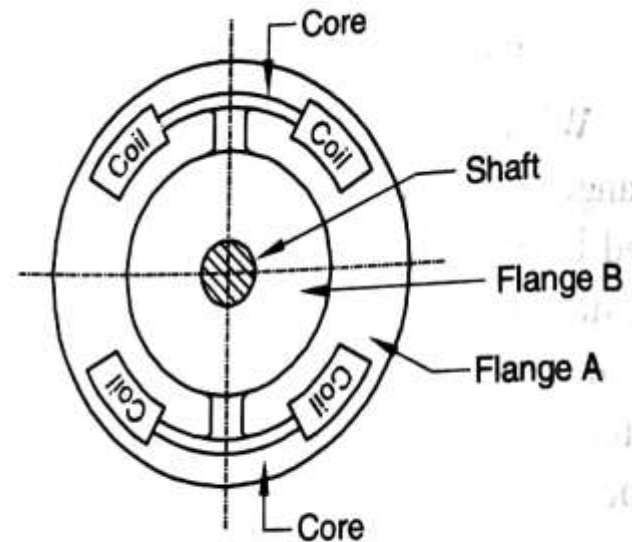

(b) Arrangement using four Inductive Transducers

THEORY:

The coil used an arm of A.C bridge .

The displacement is depend upon torque.

The bridge output can be directly calibrated to read the torque.

The output of the A.C bridge is depend upon the inductance of the coil which in turn depends upon the position of core and hence on the displacement.

3. Magnetostrictive transducers

These are based on the principle that the permeability of magnetic material changes when they are subjected to strain . The permeability decreases with positive strain and increases with Negative strain .

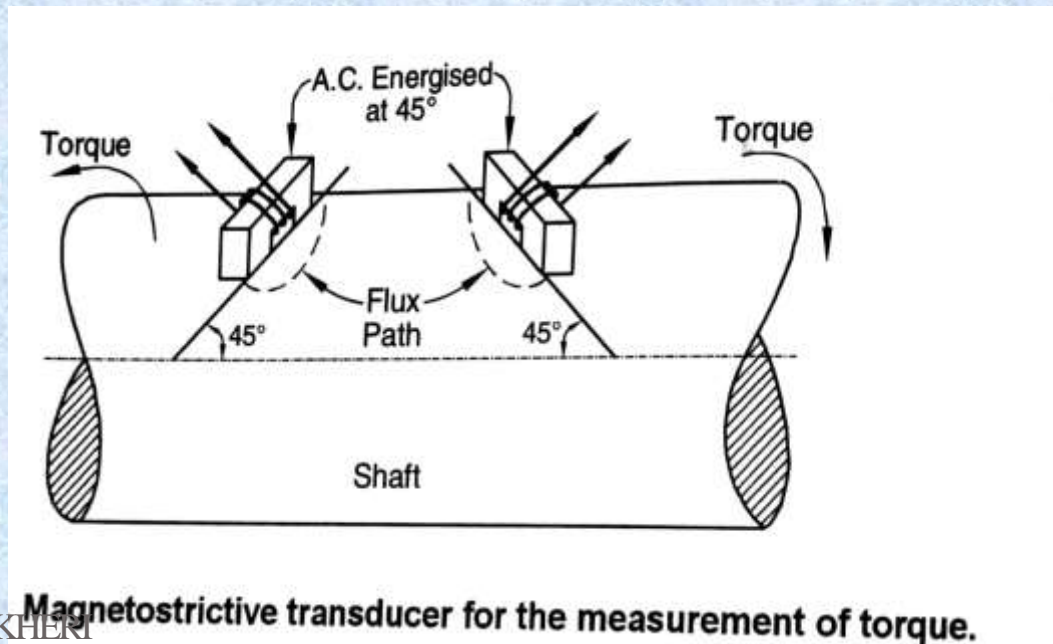

THEORY :-

Magnetostrictive transducer is used for the measurement of torque.

The inductance of one of the coil increases due to the increase in permeability.

When an torque is applied, then bridge is balanced and two coil have equal inductance.

When torque is applied , inductance of one coil increases whereas inductance of another coil is decreases and hence , bridge is unbalanced..

4. Digital methods Types:-

1. single toothed wheel system
2. Multi- toothed wheel system

Single toothed wheel system :-

Digital timing techniques are generally used for the determination of relative displacement between two flanges A and B .

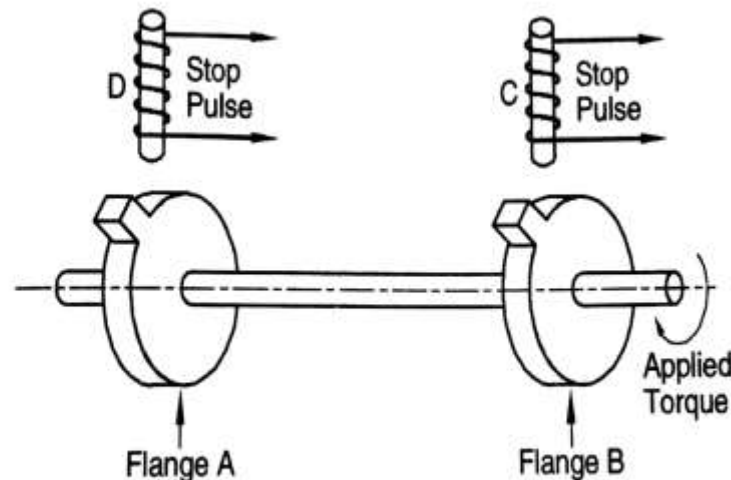

THEORY :-

When a torque is applied to the shaft, there is a relative displacement between the two flanges, and a phase shift is produced between the pulses in the inductive transducer C and D .

when these pulses are compared with the help of an electronic timer, a time interval will be displayed between the two pulses. this time interval is proportional to the relative displacement of the two flanges which in turn is proportional to the torque.

ADVANTAGE :-

1. Errors are eliminated.
2. There is no noise problem.

2. Multi toothed wheel system

Multi-toothed wheels will replace the single-toothed wheels

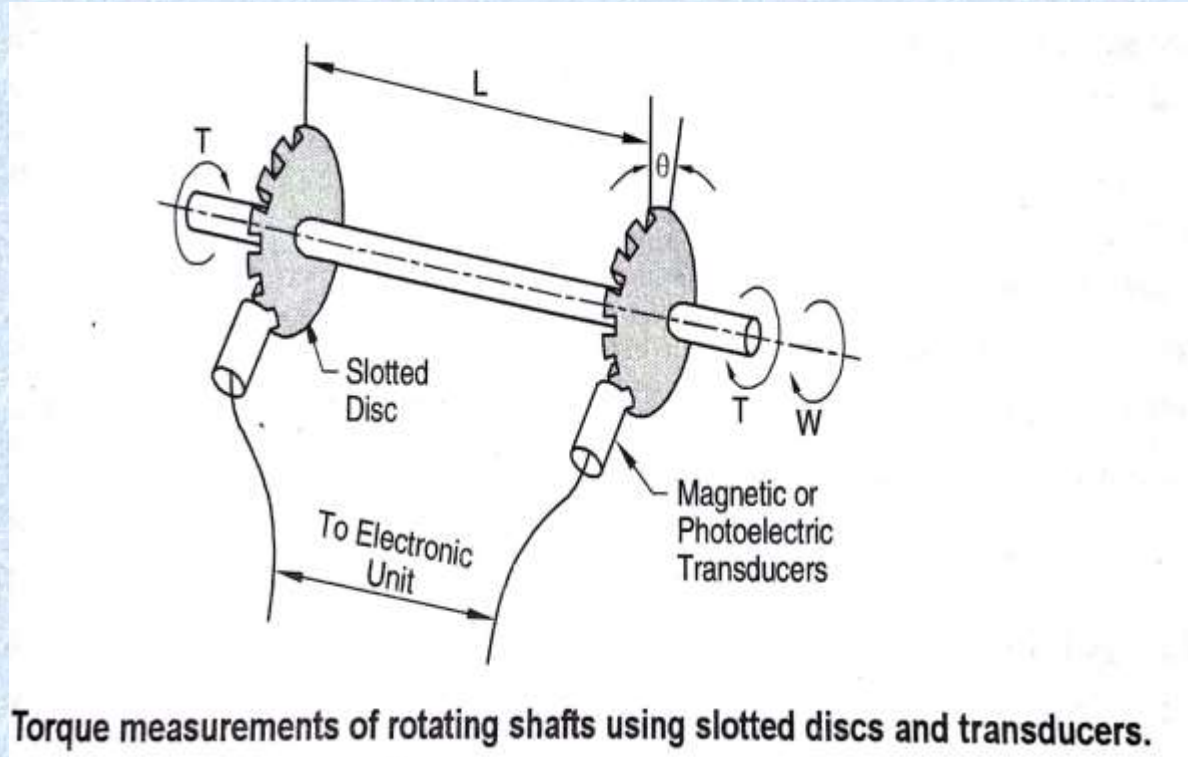

THEORY :-

The transducer are generally magnetic or photoelectric. In this case, the output is perfectly sinusoidal .

The two outputs are exactly in phase of the two wheels· are correctly.

The output voltage progressively becomes out of phase as the torque increases because an increases in torque results in relative displacement of the two flanges.

3. Torque Measurement using Prony Brake

The conventional device for the measurement of torque and dissipation of power from machines is the Prony Brake as in the diagram. Wooden blocks are mounted on a flexible band or rope, which is connected to the arm. Some arrangement is provided to tighten the rope to increase the frictional resistance between the blocks and the rotating flywheel of the machine.

The torque exerted on the Prony brake is given by $T = Fl$. The force F may be measured by conventional platform scales or other methods. The power dissipated in the brake is calculated as

$$P = 2\pi TN/60$$

where Torque is in Newton meter and N is the rotational speed in revolution per second.

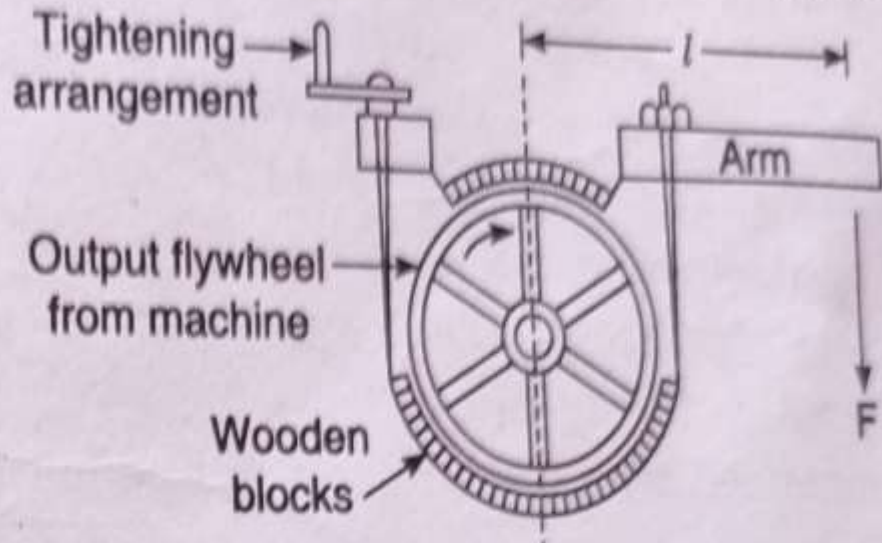

Fig. 4.12 Schematic of a Prony brake.

4. Torque Measurement using Dynamometer

A dynamometer, is a machine used to measure torque and rotational speed (rpm) from which power produced by an engine, motor or other rotating prime mover can be calculated.

A dynamometer can also be used to determine the torque and power required to operate a driven machine such as a pump. In that case, a motoring or driving dynamometer is used. A dynamometer that is designed to be driven is called an absorption or passive dynamometer. A dynamometer that can either drive or absorb is called a universal or active dynamometer.

Principles of Operation : An absorbing dynamometer acts as a load that is driven by the prime mover that is under test. The dynamometer must be able to operate at any speed, and load the prime mover to any level of torque that the test requires. A dynamometer is usually equipped with some means of measuring the operating torque and speed.

The dynamometer must absorb the power developed by the prime mover. The power absorbed by the dynamometer must generally be dissipated to the ambient air or transferred to cooling water. Regenerative dynamometers transfer the power to electrical power lines.

Dynamometers can be equipped with a variety of control systems. If the dynamometer has a torque regulator, it operates at a set torque while the prime mover operates at whatever speed it can attain while developing the torque that has been set. If the dynamometer has a speed regulator, it develops whatever torque is necessary to force the prime mover to operate at the set speed.

A motoring dynamometer acts as a motor that drives the equipment under test. It must be able to drive the equipment at any speed and develop any level of torque that the test requires.

of torque than the test...
Torque Measurement using Cradled Dynamometer : Cradled dynamometer used for torque measurement consists of motor-generator mounted on bearings, with a moment arm extending from the body of the motor to a force measurement device such as pendulum scale.

In power providing mode, it acts as a d.c. generator whose output is varied by dissipating the power in resistance racks. The torque acted on the dynamometer is measured with moment arm and output P is calculated as

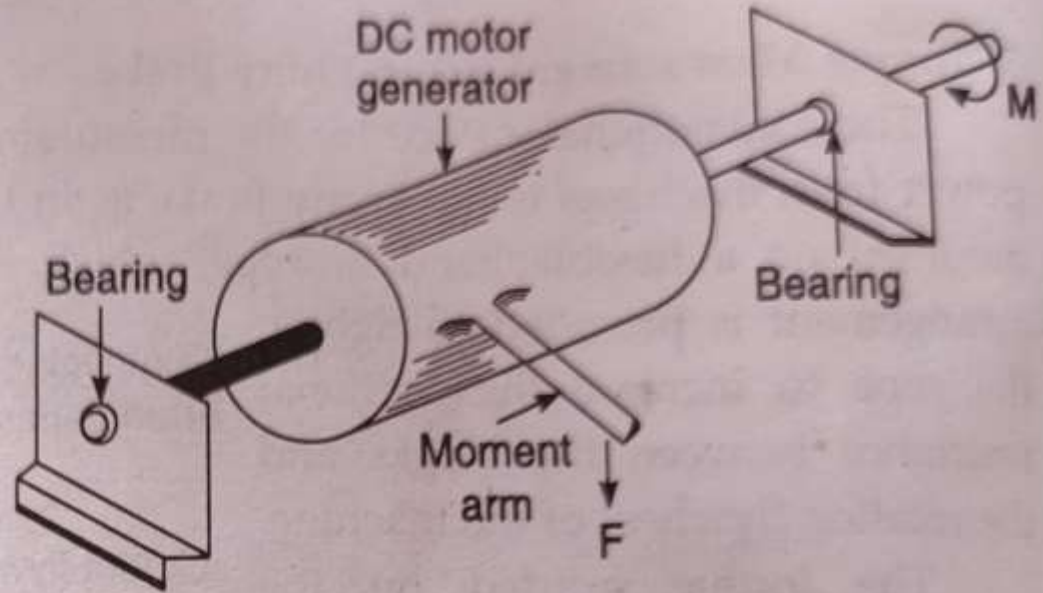

Fig. 4.13 Cradled dynamometer.

$$P = \frac{2\pi TN}{60}$$

The dynamometer can also be used as an electric motor whose power is absorbed by device like pump. Thus, torque and power input to machine is measured.

MEASUREMENT OF SPEED

MEASUREMENT OF ANGULAR VELOCITY

- In many cases the only way to measure linear velocity is to convert it into angular velocity.
- For example a speedometer uses the wheel rotational speed as a measure of the linear road speed.
- The disadvantage with measurement of linear velocity arises because a fixed reference must be used
- and if the moving object has to travel large distances, the detection becomes impossible.
- Hence angular velocity transducers are used.
- The measurement of angular speed may be made with tachometers which may be either mechanical or electrical type.

Electromagnetic Tachometer Generators

- i. D.C. tachometer generators, and
- ii. A.C. tachometer generators.

D.C. Tachometer Generators

- D.C. tachometer generators consist of a small armature which is coupled to the machine whose speed is to be measured.
- This armature revolves in the field of a permanent magnet.
- The emf generated is proportional to the product of **flux and speed**.
- Since **the flux of the permanent magnet is constant, the voltage generated is proportional to speed**.
- The polarity of output voltage indicates the direction of rotation.
- This emf is measured with the help of a moving coil voltmeter having a uniform scale and calibrated directly in terms of speed.

A series resistance is used in the circuit for the purpose of limiting the current from the generator in the event of a short circuit on the output side.

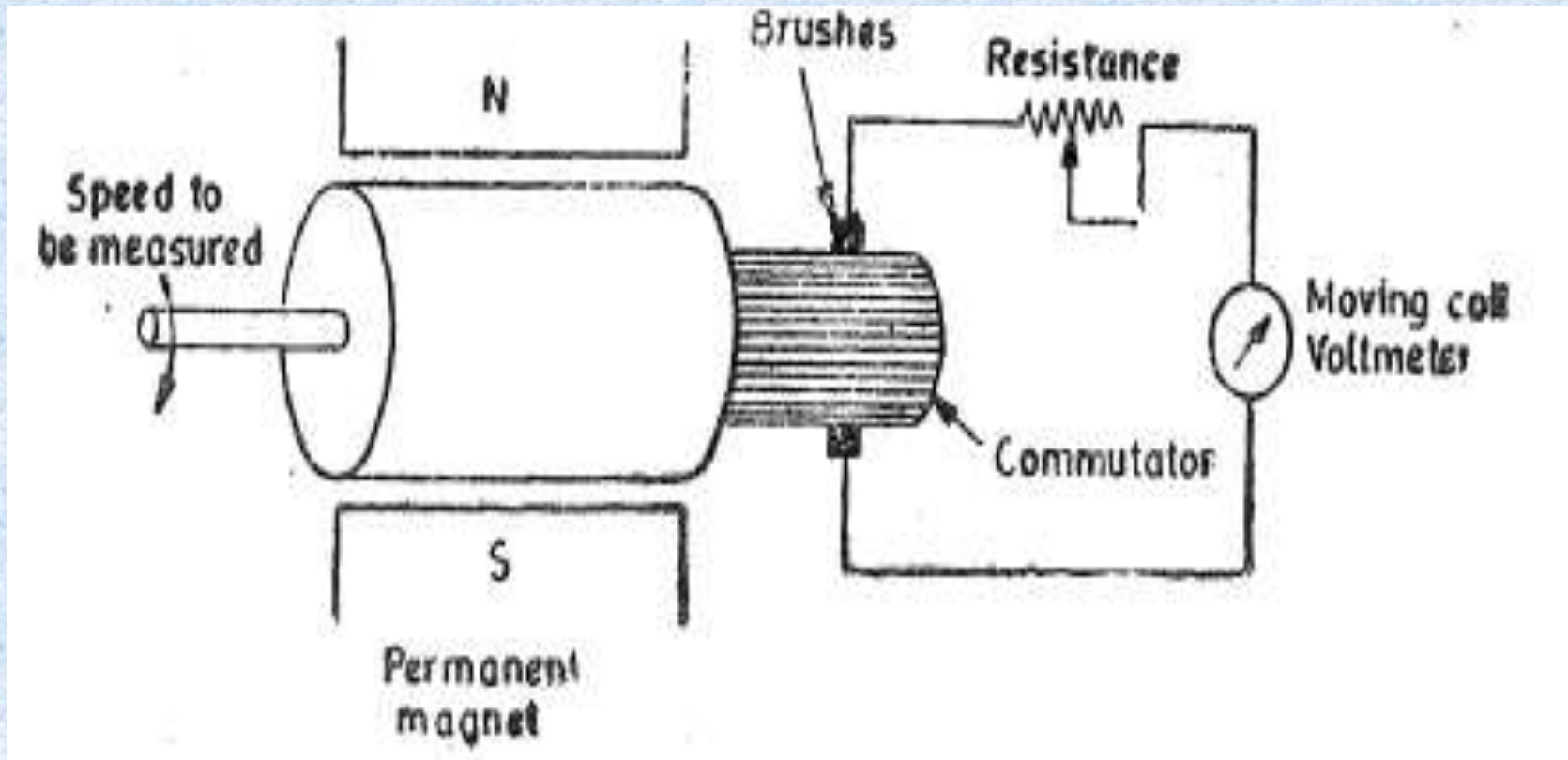

● Advantages:

- i. The direction of rotation is directly indicated by the polarity of the output voltage.
- ii. The output voltage is typically 10 mV/rpm and can be measured with conventional type d.c. voltmeters.

● Disadvantages:

- iii. Brushes on small tachometer generators often produce maintenance problems, as their contact resistance may vary and produce appreciable error. Thus the commutator and the brushes require periodic maintenance.
- iv. The input resistance of meter should be very high as compared with output resistance of generator. This is required to limit the armature current to small value. If the armature current is large, the field of the permanent magnet is distorted giving rise to non-linearity.

A.C. Tachometer Generators

- The tachometer generator has rotating magnet which may be either a permanent magnet or an electromagnet.
- The coil is wound on the stator and therefore the problems associated with commutator (as in d.c. tachometers) are absent.
- The rotation of the magnet causes an emf to be induced in the stator coil.
- The amplitude and frequency of this emf are both proportional to the speed of rotation.
- Thus either amplitude or frequency of induced voltage may be used as a measure of rotational speed.

When amplitude of induced voltage is used as a measure of speed, the circuit of Fig. is used.

The output voltage of a.c. tachometer generator is rectified and is measured with a permanent magnet moving coil instrument.

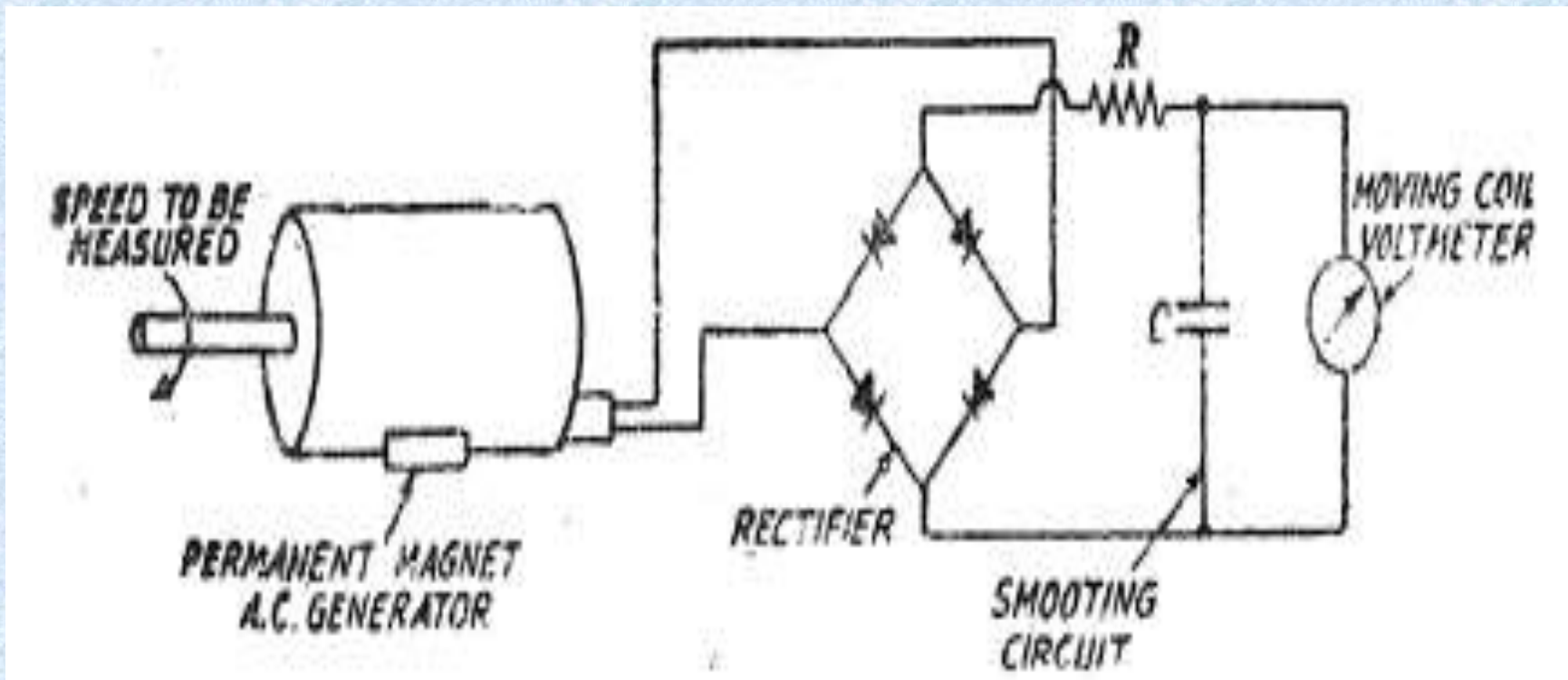

● Limitations:

- i. The difficulty with this system is that at low speed the frequency of output voltage is low and hence it is very difficult to smooth out the ripples in the output voltage wave shape and hence a.c. tachometer generators are designed to have a large number of poles so that the frequency of output voltage is high even at low speeds.
- ii. At high speeds, the frequency increases and therefore, the impedance of the coils of tachogenerator increases. If good linearity is to be maintained the input impedance of the display device must be considerably larger than the impedance of the coils.

Drag Cup Rotor A.C. Tachogenerator

- The tachogenerator consists of a stator and a rotor. The stator has two windings mounted at 90° to each other.
- The two stator windings are : (i) excitation winding, and (ii) *sensing winding*.
- An alternating current voltage is applied to the excitation winding, while the output is taken from the sensing winding.
- The rotor is made up of a thin aluminium cylinder which is called a drag cup.
- This light inertia rotor is highly conducting and acts as short circuited secondary winding. A low reluctance path is provided by a ferromagnetic core.

The rotation of the rotor causes an induced voltage in the sensing winding and this voltage is proportional to the instantaneous value of speed if the excitation frequency is very large as compared with speed.

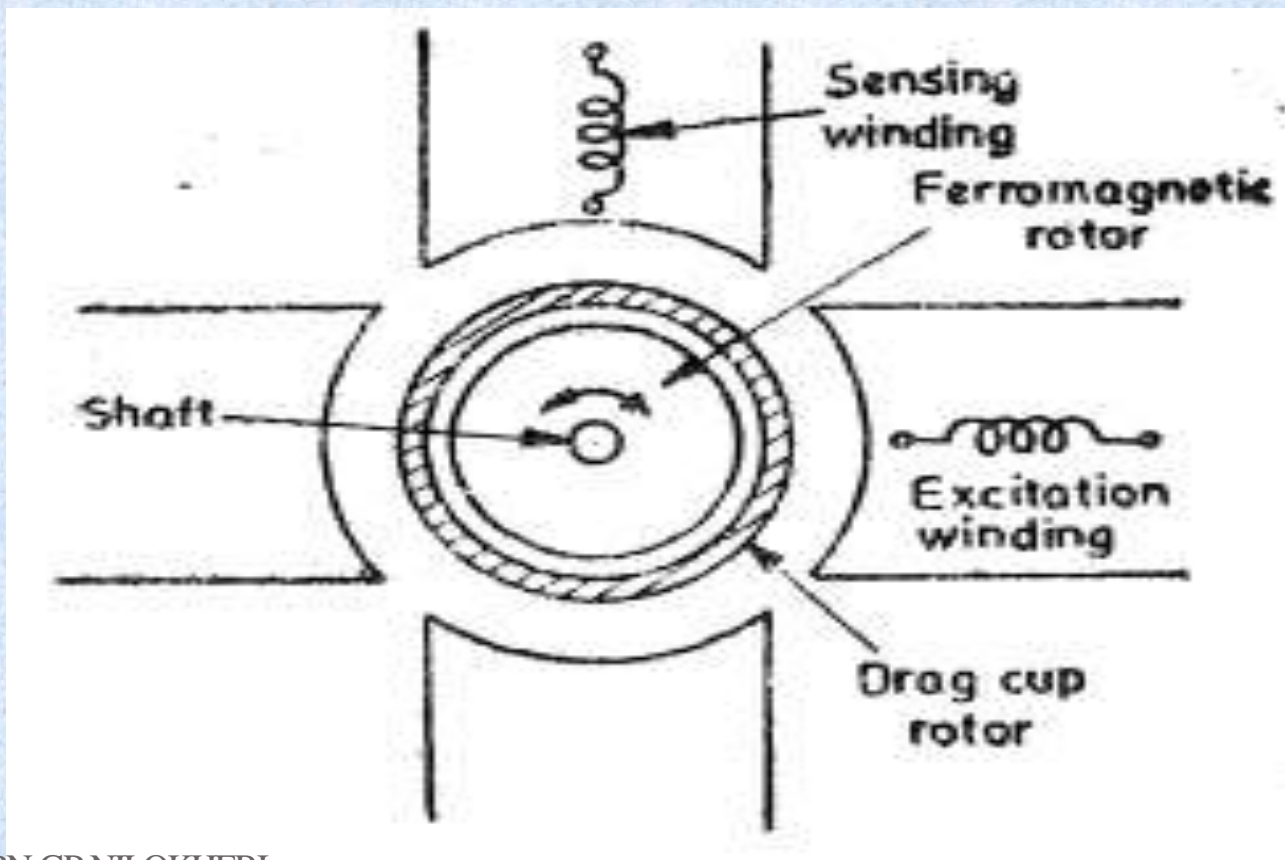

Digital Methods

- The electromechanical methods for measurement of angular velocity are satisfactory up to about a speed of 10,000 rpm.
- Higher speed measurements are possible with digital pickups which work in conjunction with digital frequency meters
- The biggest advantage of digital methods is that no direct physical contact is required with the shaft whose speed is to be measured. Therefore, no load is imposed upon the shaft by measuring device.
- The digital pickups are of two types: (i) photo-electric type, and (ii) *inductive type*.

Photoelectric Tachometer

- This method of measuring speed of rotation consists of mounting an opaque disc on the rotating shaft as is shown in Fig.

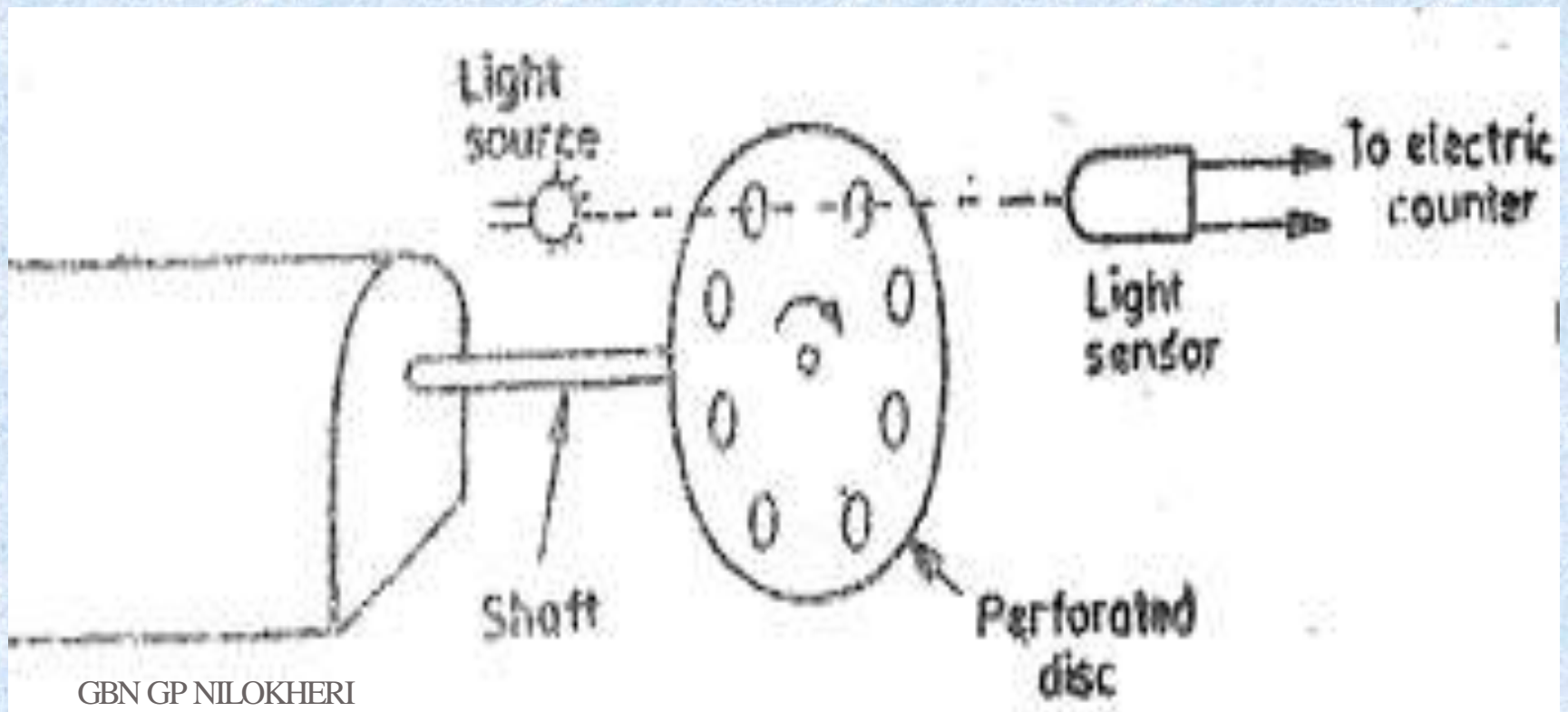

- The disc has a number of equidistant holes on its periphery. At one side of the disc a light source is fixed and at the other side of the disc, and on line with the light source, a light sensor such as a photo tube or some photosensitive semiconducting device is placed.
- When the opaque portion of the disc is between the light source and the light sensor, the latter is unilluminated and produces no output.
- But when a hole appears between the two, the light falling upon the sensor produces an output pulse.
- **The frequency at which these pulses are produced depends upon the number of holes in the disc and its speed of rotation.**
- **Since the number of holes is fixed, the pulse rate is a function of speed of rotation.**
- The pulse rate can be measured by an electronic counter which can be directly calibrated in-terms of speed in rpm.

Advantages

- i. The output format is digital and this means that if the tachometer is a part of a digital instrumentation system, no analog to digital conversion is necessary.
- ii. The pulse amplitudes are constant. This simplifies the electronic circuitry.

Disadvantages

- i. A disadvantage is that the light source must be replaced from time to time. A typical life time for light source is 50,000 hours.
- ii. The accuracy of this method depends principally on the error represented by one pulse. The digital meters measure frequency by counting the number of input pulses which occur in short period of time called **gating period**. If this period is too small serious errors may be caused. The gating period should therefore, be chosen to give a sufficiently large count. In general, all the digits on the digital display should be utilized. The factors which the user can control to minimize the errors are :
 - (i) gating period, and
 - (ii) number of pulses generated per revolution.

Toothed rotor variable reluctance tachometer

- This tachometer generator consists of a metallic toothed rotor mounted on the shaft whose speed is to be measured. A magnetic pickup is placed near the toothed rotor.

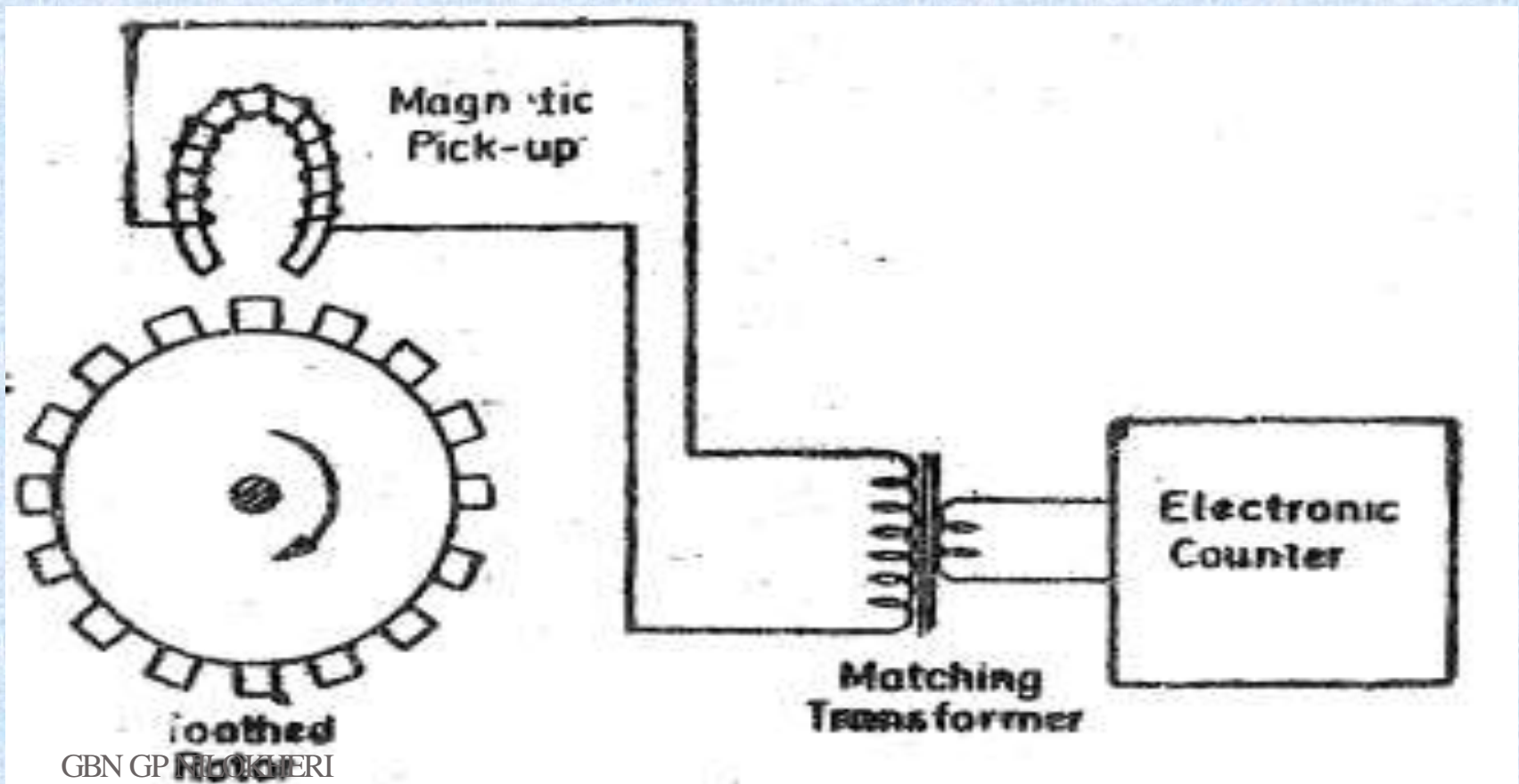

- The magnetic pick up consists of a housing containing a small permanent magnet with a coil wound round it.
- When the rotor rotates, the reluctance of the air gap between pickup and the toothed rotor changes giving rise to an induced emf. in the pickup coil. This output is in the form pulses, with a variety of wave shapes.
- **The frequency of the pulses of induced voltage will depend upon the number of teeth of the rotor and its speed of rotation.**
- **Since the number of teeth is known, the speed of rotation can be determined by measuring the frequency of pulses with an electronic counter.**

- Suppose the rotor has T teeth, the speed of rotation is n rps and number of pulses per second is P .

. '. Number of pulses per revolution = T .

- Hence speed $n = \frac{\text{pulses per second}}{\text{number of teeth}} = \frac{P}{T} \text{ rps} = \frac{P}{T} \times 60 \text{ rpm}$

- A typical rotor has 60 teeth. Thus if the counter counts the pulses in one second, the counter will directly display the speed in rpm.

Advantages

- (i) It is simple and rugged in construction.
- (ii) It is maintenance free.
- (iii) It is easy to calibrate. This has been illustrated earlier, if the rotor has 60 teeth and the pulses are counted by counter in one second, the count displayed by the counter gives the speed directly in r.p.m.
- (iv) The information from this device can be easily transmitted.

Stroboscope

- The stroboscope is a simple, portable manually operated device which may be used for measurement of periodic or rotary motions.
- Basically, the instrument is a source of variable frequency flashing brilliant light, the flashing frequency being set by the operator.
- The circuit used is based upon variable frequency oscillator which controls the flashing frequency.
- The speed is measured by adjusting the frequency so that the moving objects are visible only at specific intervals of time.
- The method of use of the stroboscope depends upon imperfect dynamic response of human eye.
- If a strong light is caused to flash on a moving object which, at the time each flash occurs, occupies a given position, the object will appear to be stationary.
- Therefore the method is useful for only those types of motions which occur regularly after a fixed interval of time, such as oscillation or rotation.

The stroboscope consists of a source of flashing light whose frequency can be varied and controlled. This source is called a strobotron.

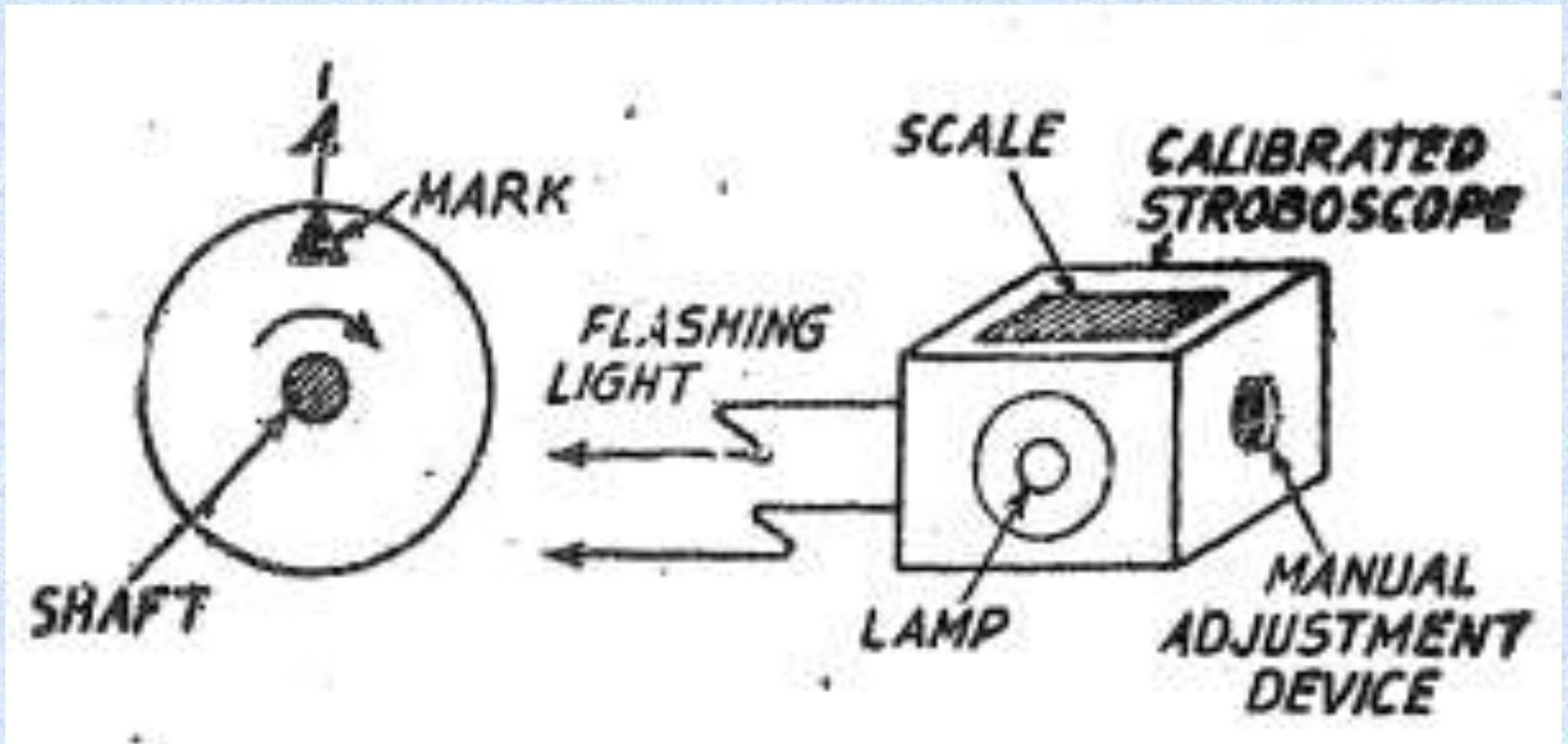

Shaft Speed Measurements

- A distinctive mark is made on the shaft or on a disc attached to the shaft as shown in Fig.
- A stroboscope is made to flash light directly on the mark.
- The flashing frequency is adjusted until the mark appears stationary.
- Under these conditions, the speed is equal to the flashing frequency provided that the approximate speed of the shaft is known in advance and the flashing frequency is not allowed to depart too much away from this value.
- The scale of the stroboscope is calibrated in terms of speed which can be directly read off.
- If the two conditions outlined above are not met or if there are several identical marks on the shaft like spokes of a wheel or jaws of a chuck, serious errors in the measurement may arise.

Advantages

- i. This method imposes no load on the shaft.
- ii. It requires no special attachments with the shaft.
- iii. This method is particularly useful where it is inconvenient or impossible to make contact with the shaft.
- iv. It is very convenient to use a stroboscope for spot checks on machinery speeds and for laboratory work.

Disadvantages

- i. The circuit of the variable frequency oscillator cannot be stabilized to give a fixed frequency. Therefore, this method is less accurate than the methods utilizing digital meters.
- ii. The stroboscope cannot be used in surroundings where the ambient light is above a certain level. The stroboscope requires subdued lighting conditions for efficient operation.

Unit-6

Flow Measurement

Flow Meter

- A flow meter is a device used to measure the volume or mass of a gas or liquid. OR
- A **flow meter** is an instrument used to measure linear, nonlinear, mass or volumetric flow rate of a liquid or a gas or fluid. OR
- A flow meter works by measuring the amount of a liquid, gas, or steam flowing through or around the flow meter sensors.

Electromagnetic Flow Meter

● Introduction

A **Electromagnetic flow meter** is a volumetric flow meter which does not have any moving parts and is ideal for wastewater applications or any dirty liquid which is **conductive** or water based.

● Working Principle

The operation of a **Electromagnetic flow meter** is based upon **Faraday's Law**, which states that:

“The voltage induced across a conductor as it moves at right angles through the magnetic field is proportional to the velocity of that conductor.”

According to this law the induced **voltage E** is proportional to **$V \times B \times L$** . Where: **E**= The voltage generated in a conductor

V= The velocity of the conductor

B= The magnetic field strength

D= The length of the conductor (in this instance distance between the electrodes)

- Electromagnetic flowmeter use Faraday's Law of electromagnetic induction to determine the flow of liquid in a pipe. In a magnetic flowmeter, a magnetic field is generated and channeled into the liquid flowing through the pipe. Following Faraday's Law, flow of a conductive liquid through the magnetic field cause a voltage signal to be sensed by electrodes located on the flow tube walls.

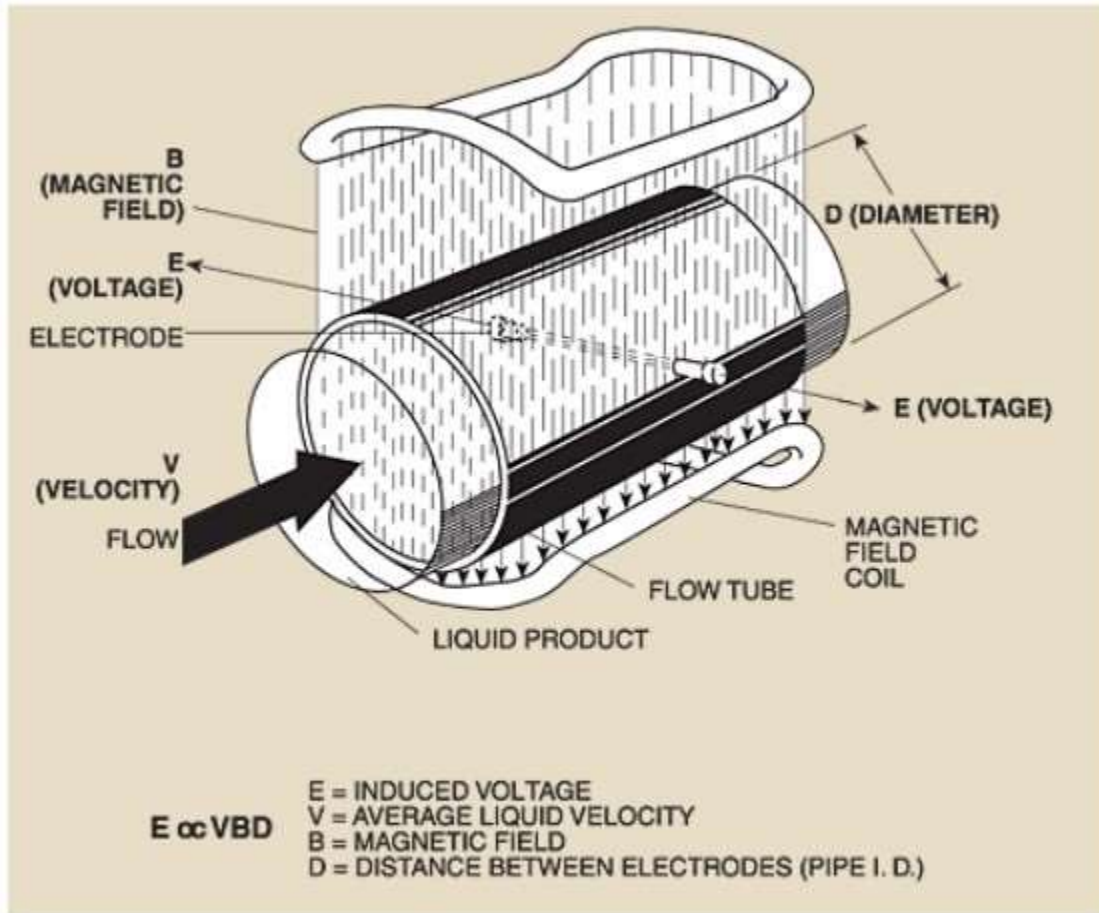

Advantages, Disadvantages & Uses

Advantages:

- Minimum obstruction in the flow path yields minimum pressure drop.
- It can measure forward as well as reverse flow with equal accuracy.
- Low maintenance cost because of no moving parts.
- Corrosive or slurry fluid flow.

Disadvantage:

- Requires electrical conductivity of fluid.
- Zero check can only be done when there is no flow.

Uses

Water supply in domestic or irrigation

CNG gas pipeline

Refineries etc.

ULTRASONIC FLOW METERS

- Two different types of ultrasonic flowmeters employ distinct technologies, one based on Doppler shift and other on transit time.
- The principle of operation of the Doppler shift flow meter is shown in figure. It consists of a piezoelectric transmitter and receiver. The transmitter sends ultrasonic waves into the liquid through a particular direction.

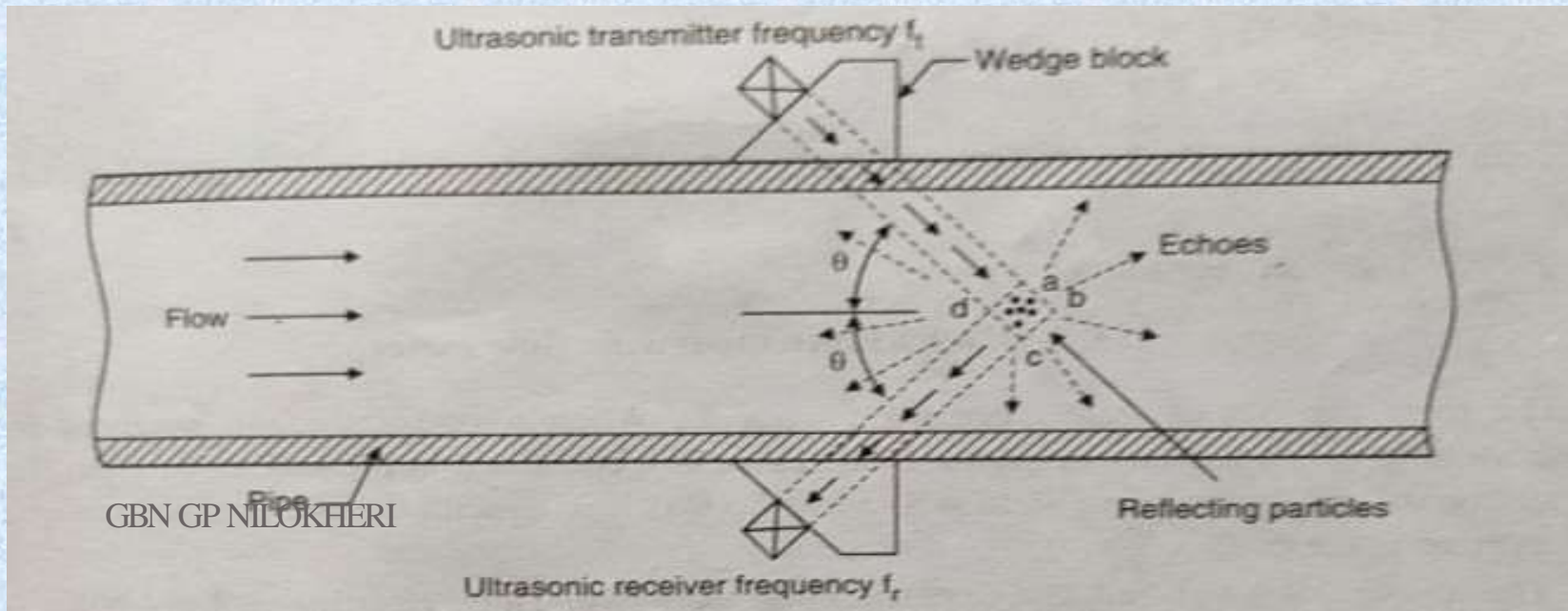

- These pass through the wedge block and strike the liquid particles. Echoes are produced due to this striking which are reflected in all directions.
- The receiver is mounted on another wedge. This picks up echoes from particles which are in the region 'abcd' only.
- The process is described mathematically by the following expression:

$$f_t - f_r = \frac{2f_t \cos \theta}{c} \times v$$

f_t = Transmitter frequency

f_r = Receiver frequency

θ = Angle between flow direction and transmitter/ receiver wave

C = Speed of sound in liquid

V = Velocity of particles of liquid

- Thus , the unknown parameter v (flow rate) can be determined.

Transit Time Flowmeter

- **Principle of Operation**
- The acoustic method of discharge measurement is based on the fact that **the propagation velocity of an acoustic wave and the flow velocity are summed vectorially.**
- **This type of flowmeter measures the difference in transit times between two ultrasonic pulses transmitted upstream t_{21} and downstream t_{12} across the flow.**
- If there are no transverse flow components in the conduit, these two transmit times of acoustic pulses are given by:

$$t_{12} = \frac{L_w}{c + v_a \cos \varphi}$$

$$t_{21} = \frac{L_w}{c - v_a \cos \varphi}$$

Time difference $\Delta t = \frac{2vL \cos \varphi}{C^2 - v^2 \cos 2\varphi}$

Measurement of Temperature

- Temperature is defined as the degree of hotness or coldness of a body or an environment measured on a definite scale. OR
- A condition of a body by virtue of which heat is transferred to or from other bodies.
- Different scales of temperature are °Celsius, Fahrenheit, Rankin, Kelvin scales.
- $^{\circ}\text{F} = 32 + \frac{9}{5} \text{ C}$
- $\text{R} = \frac{9}{5} \text{ K}$

Measurement of Temperature

Temperature measurement methods can be classified as:

- Non-electrical methods- can be used on one of the following principles;
 - i. Change in the physical state
 - ii. Change in the chemical properties and
 - iii. Change in the physical properties
- Electrical methods- are preferred for the measurement of temperature as they furnish a signal which can be easily detected, amplified or used for control purposes.
- Radiation methods- radiation technique is used for temperature measurement where the thermometers, RTDs, thermistors cannot be brought in contact with process media because of possible damage or when hot body is a moving mass.

Bimetallic Thermometer

- These thermometers used two fundamental principles:
 - i. All metals expand or contract with the change in temperature and
 - ii. The temperature co-efficient of expansion is not the same for all metals and therefore their rate of expansion or contraction are different. The difference in thermal expansion rates is used to produce deflection proportional to the temperature changes.

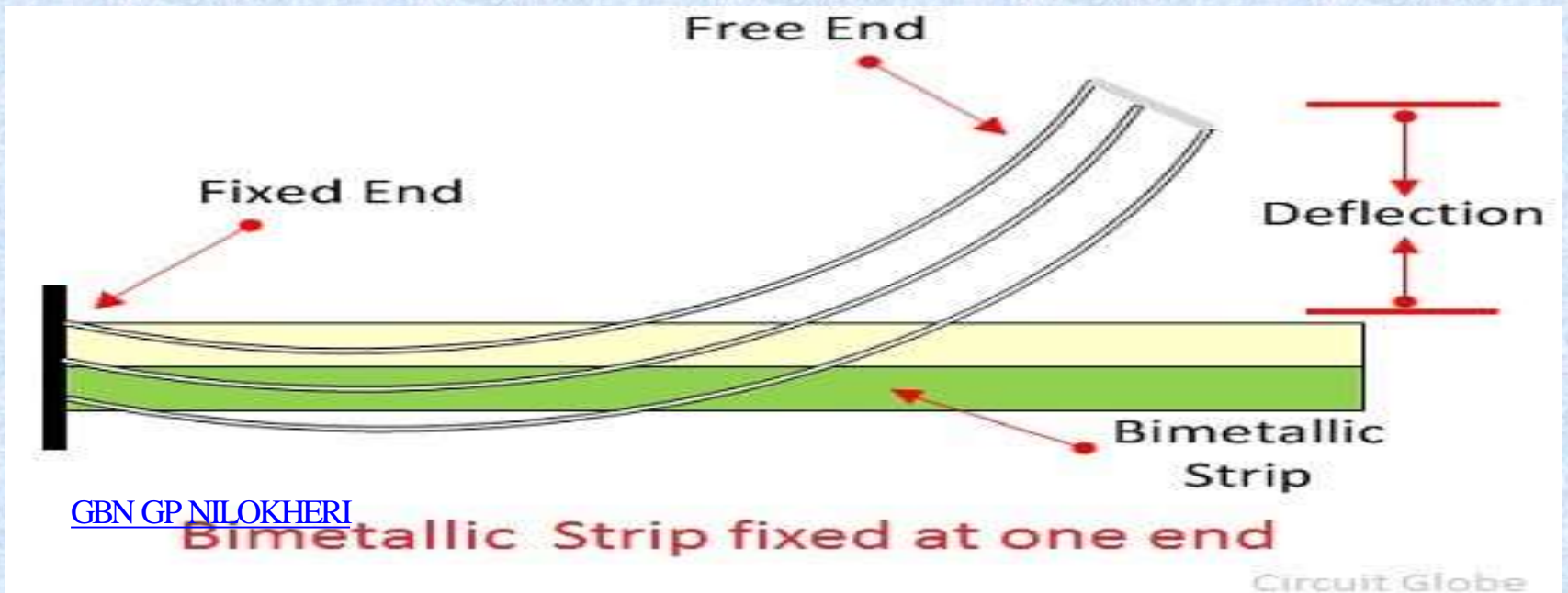

Bimetallic Thermometer

- A bimetallic thermometer consists of a strip which is constructed by bonding together two thin strips of two different metals such that they cannot move relative to each other. These two metallic strips change their lengths at different rates when subjected to same temperature.
- With one end fixed as in fig., the temperature changes cause the free end to deflect.
- The range over which a linear deflection exists between deflection and temperature depends upon the combination of metals used for the bimetallic strip.
- The deflection of free end is directly proportional to temperature change and square of the length of strip and inversely proportional to the thickness along linear portion of deflection temperature characteristics.

In bimetallic thermometer the strip is in the form of spiral or helix .

A pointer is attached at the end. The pointer shows temperature on circular scale.

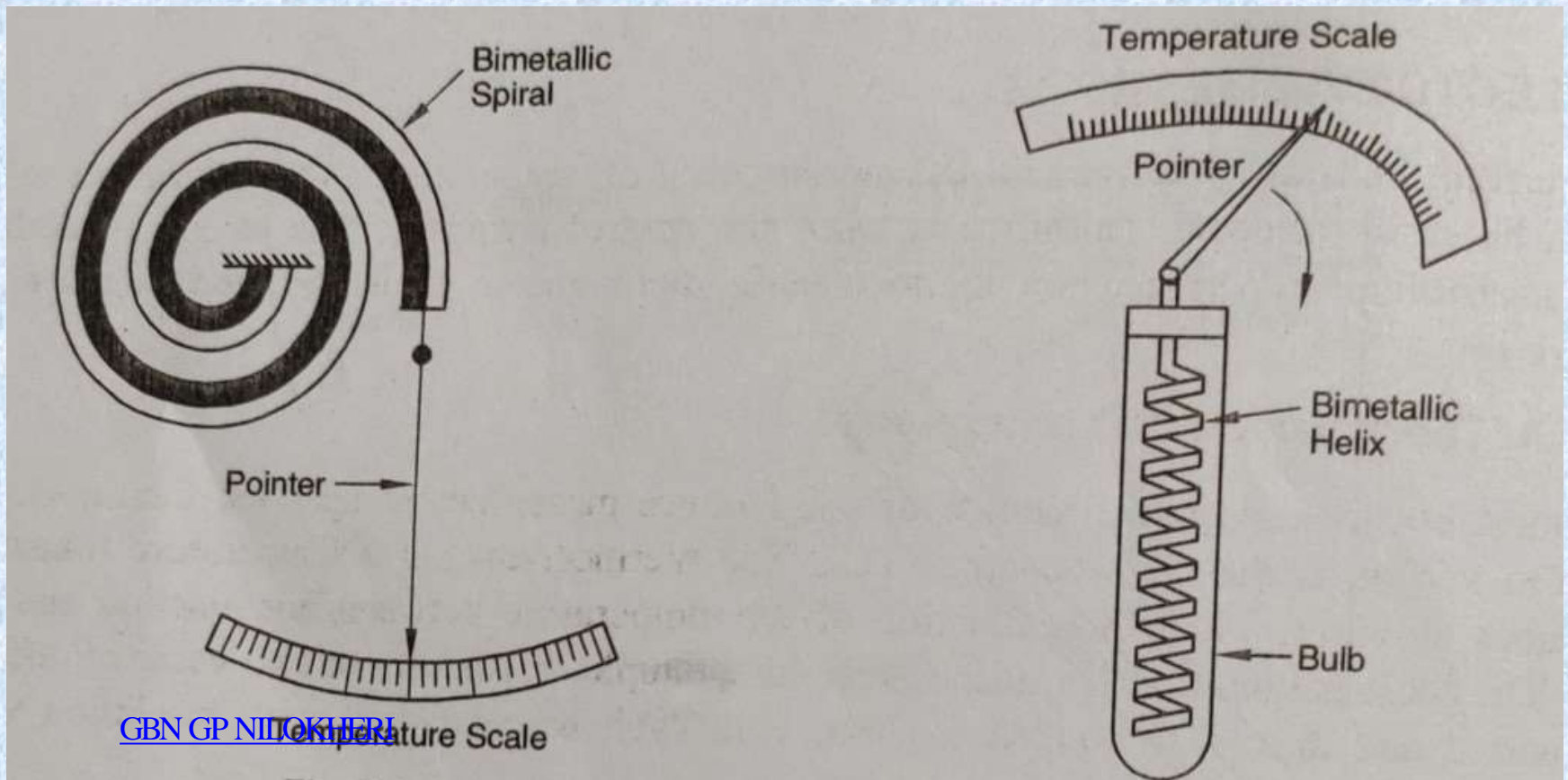

Advantages:

- Bimetallic thermometers are simple, robust and inexpensive.
- These thermometers have accuracy range from $\pm 0.5\%$ for laboratory type and about $\pm 2\%$ for process type instruments.
- They can withstand about 50% over-range in temperature.

Disadvantages:

- Bimetallic thermometer are not recommended for use at temperature above $400\text{ }^{\circ}\text{C}$ for continuous duty to above $550\text{ }^{\circ}\text{C}$ for instruments duty.
- All metals have physical limitations and are subjected to permanent warp distortion.

Applications:

- Bimetallic thermometers are used in refineries, oil burners, hot solder tanks, hot wire heaters, temperature tanks and impregnating tanks etc.

Resistance thermometer (RTD)

- The resistance of a conductor changes when its temperature is changed. This property is utilized for temperature measurement.
- The variation of resistance R with temperature for most of metals

as:

$$R = R_0(1 + \alpha_1 T + \alpha_2 T^2 + \dots \alpha_n T^n + \dots)$$

where R_0 = resistance at temperature $T = 0$.

and $\alpha_1, \alpha_2, \alpha_3, \dots, \alpha_n$ are constants.

- The resistance thermometer uses the change in electrical resistance of the conductor to determine the temperature.

Some requirement of conductor material used in resistance temperature detector (RTD)

- i. High temperature co-efficient of resistance.
- ii. High resistivity.
- iii. Linearity over a sufficient range of temperature.
- iv. Stability of electrical characteristics.

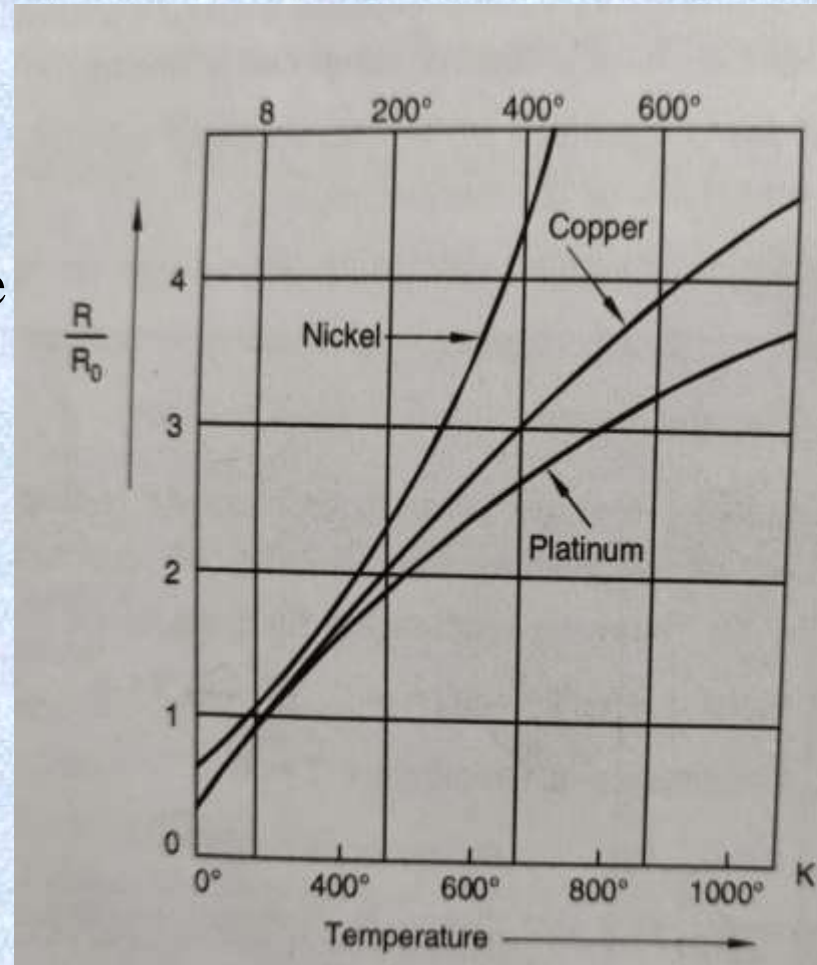

Platinum resistance thermometer

Platinum is the most common choice because of following properties:

- Its inertness to foreign chemicals.
- Its Linear resistance change with temperature.
- Its high Temperature coefficient of resistance. This avoids any sudden spike in resistance with respect to applied temperature.
- Its stability. The platinum is kept in metallic tube casing. The leads are taken out for connection. Threads are provided for mounting purpose.

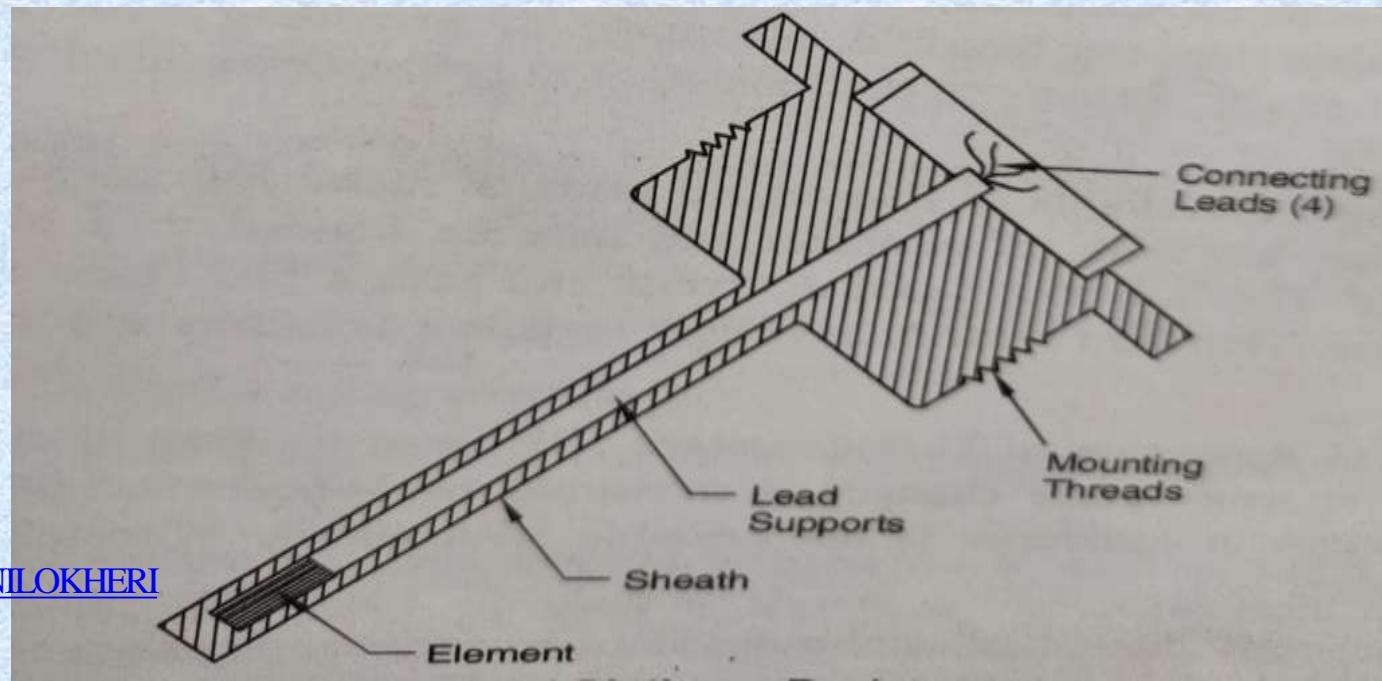

Measurement of resistance of thermometers

The measurement of change of resistance of thermometer due to temperature changes is measured by Wheatstone bridge.

One simple circuit is the quarter bridge Wheatstone bridge circuit, here called a *two-wire RTD bridge circuit*.

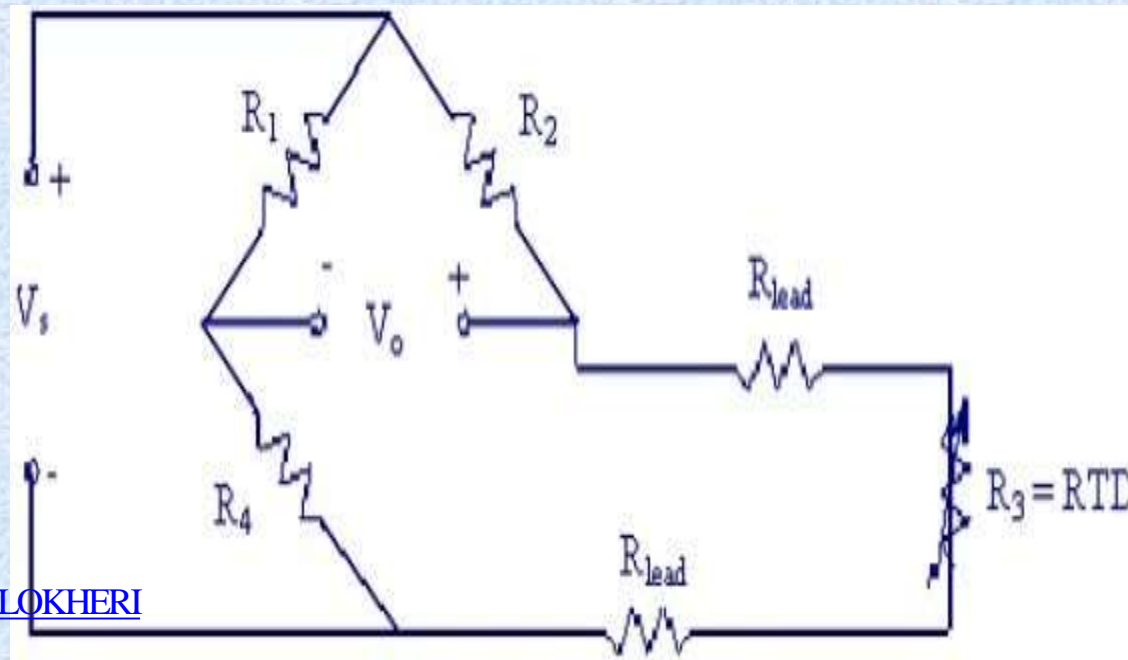

But, for the measurement of changes in resistance is not possible with simple Wheatstone bridge due to following disadvantages:

- The contact resistance of adjustable standard resistor may be large enough to produce an error when measuring the change in resistance of thermometer.
- The lead from thermometer to the bridge may introduce an error due to change of their resistance produced by temperature changes.
- The current through the thermometer produces a heating effect equal to the product of current squared and the resistance of thermometer.

Wheatstone bridge with some modification, such as double slide Wire Bridge removes most of these errors.

- **Three lead methods:** A double slide wire bridge is shown in fig. It has two slide wire resistor S_1 and S_2 which are tied together so that the fraction of S_1 in series with the resistance R_2 is equal to fraction of S_2 in series with resistance R_3 . There are three equal leads from the thermometers to the bridge. The resistance of each lead is R_L . Since, there are three leads coming out of the resistance thermometers, the method is known as three lead methods.

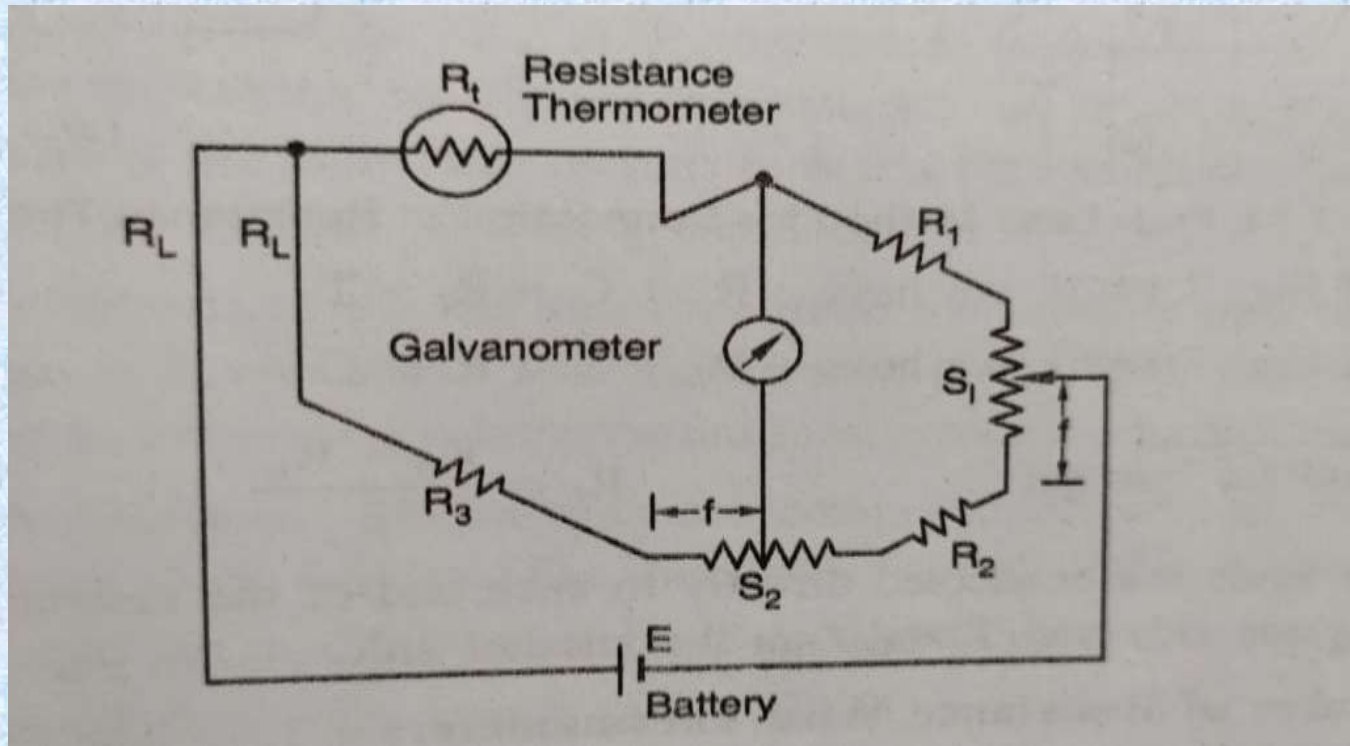

- **Where high accuracy is required, four lead methods are used instead of two or three lead methods.**

THERMISTOR

- The thermistor is a kind of resistor whose resistivity depends on surrounding temperature.
- It is a temperature sensitive device. The word thermistor is derived from the word, **thermally sensitive resistor**.
- The thermistor is made of the semiconductor material that means their resistance lies between the conductor and insulator.
- Thermistors act as a passive component in a circuit. They are an accurate, cheap, and robust way to measure temperature.

Types of Thermistor

- The thermistor is classified into types. They are the negative temperature coefficient and the positive temperature coefficient thermistor.
- **Negative Temperature Coefficient Thermistor** – In this type of thermistor the temperature increases with the decrease of the resistance. The resistance of the negative temperature coefficient thermistor is very large due to which it detects the small variation in temperature.
- **Positive Temperature Coefficient Thermistor** – The resistance of the thermistor increases with the increases in temperature.

NTC Thermistor

In an NTC thermistor, when the temperature increases, resistance decreases. And when temperature decreases, resistance increases. Hence in an NTC thermistor temperature and resistance are inversely proportional. These are the most common type of thermistor. The relationship between resistance and temperature in an NTC thermistor is governed by the following expression:

$$R_T = R_0 e^{\beta \left(\frac{1}{T} - \frac{1}{T_0} \right)} \quad (1)$$

Where:

- R_T is the resistance at temperature T (K)
- R_0 is the resistance at temperature T_0 (K)
- T_0 is the reference temperature (normally 25°C)
- β is a constant, its value is dependent on the characteristics of the material. The nominal value is taken as 4000.

If the value of β is high, then the resistor–temperature relationship will be very good. A higher value of β means a higher variation in resistance

Construction of Thermistor

- The thermistor is made with the sintered mixture of metallic oxides like manganese, cobalt, nickel, cobalt, copper, iron etc. It is available in the form of the bead, rod and disc. The different types of the thermistor are shown in the figure below.

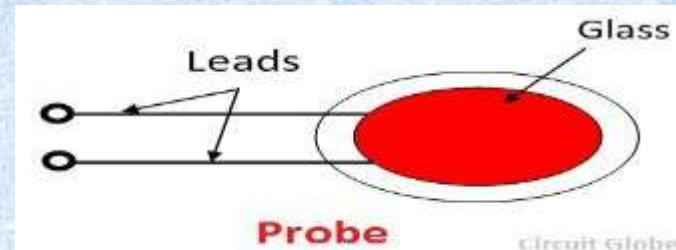
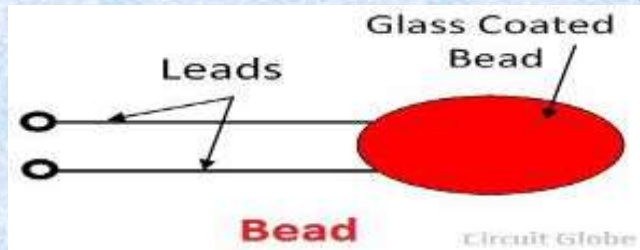

- The bead form of the thermistor is smallest in shape (.015 to 1.25mm) and it is enclosed inside the solid glass rod to form probes.
- The disc shape is made by pressing material under high pressure with diameter range from 2.5 mm to 25mm.

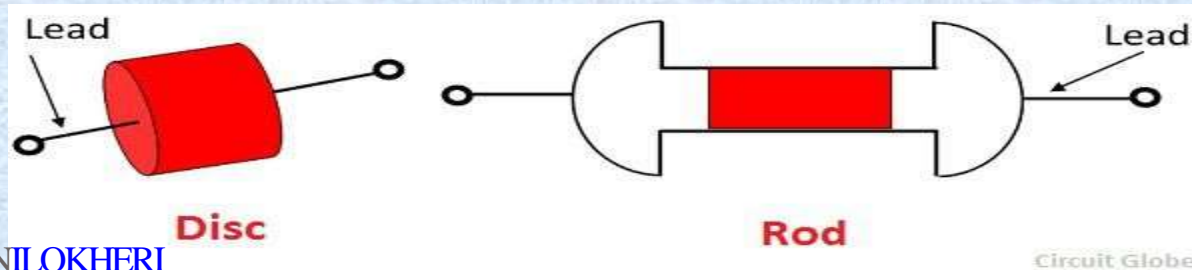

Resistance Temperature Characteristic of Thermistor

- The relation between the absolute temperature and the resistance of the thermistor is mathematically expressed by the equation shown below.

$$R_{T_1} = R_{T_2} \exp \left[\beta \left(\frac{1}{T_1} - \frac{1}{T_2} \right) \right]$$

- Where R_{T_1} – Resistance of the thermistor at absolute temperature T_1 in Kelvin.
 R_{T_2} – Resistance of the thermistor at absolute temperature T_2 in Kelvin.
 B – a temperature depending on the material of thermistor.
- The resistance temperature coefficient of the thermistor is shown in the figure below. The graph below shows that the thermistor has a negative temperature coefficient, i.e., the temperature is inversely proportional to the resistance. The resistance of the thermistor changes from 10^5 to 10^{-2} at the temperature between -100°C to 400°C .

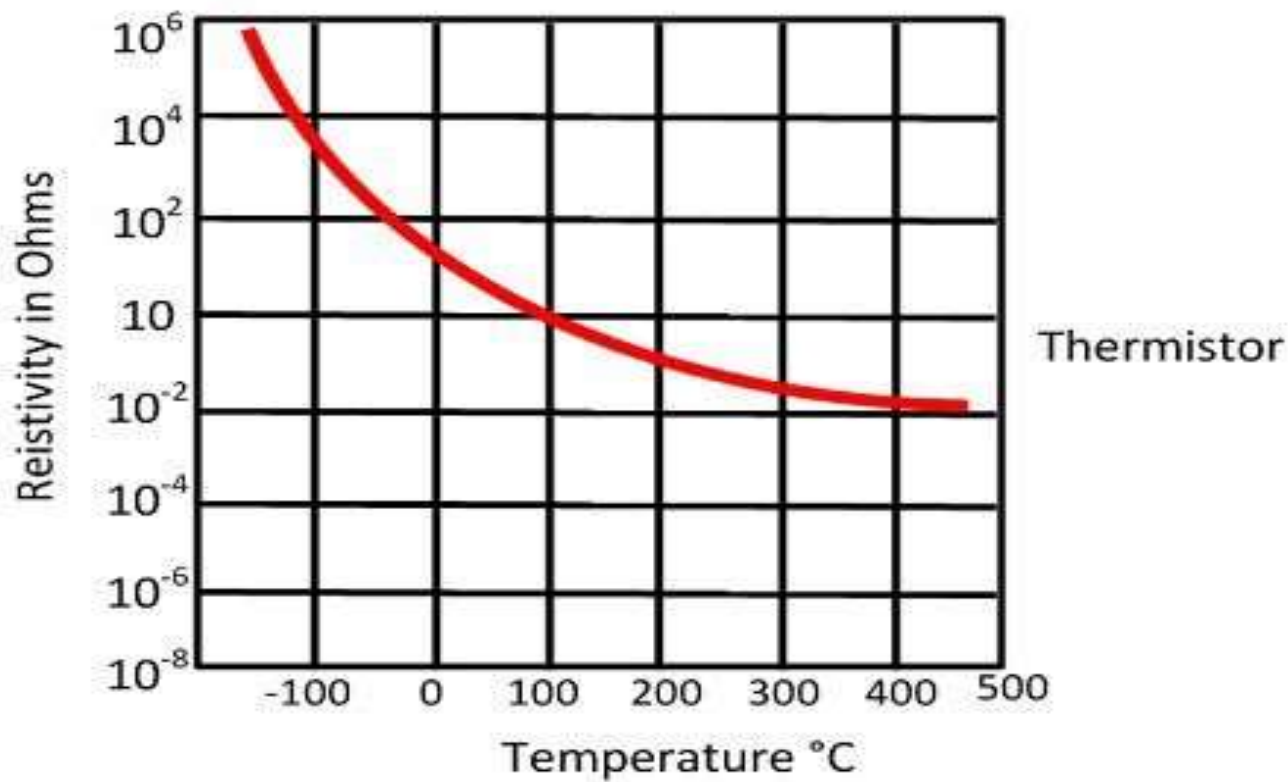

Resistance Temperature Characteristic

Circuit Globe

Thermistor vs RTD

- Resistance Temperature Detectors (also known as [RTD sensors](#)) are very similar to thermistors. Both RTDs and thermistors have varying resistance dependent on the temperature.
- The main difference between the two is the type of material that they are made of. Thermistors are commonly made with ceramic or polymer materials while RTDs are made of pure metals. In terms of performance, thermistors win in almost all aspects.
- Thermistors are more accurate, cheaper, and have faster response times than RTDs. The only real disadvantage of a thermistor vs an RTD is when it comes to temperature range. RTDs can measure temperature over a wider range than a thermistor.

Advantages of Thermistor

- The thermistor is compact, long durable and less expensive.
- The properly aged thermistor has good stability.
- The response time of the thermistor changes from seconds to minutes. Their response time depends on the detecting mass and the thermal capacity of the thermistor.
- The upper thermistor limit of the temperature depends on the physical variation of the material, and the lower temperature depends on the resistance reaching a large value.
- The self-heating of the thermistor is avoided by minimizing the current passes through it.
- The thermistor is installed at the distance of the measuring circuit. Thus the reading is free from the error caused by the resistance of the lead.

Uses of Thermistors

- Digital thermometers (thermostats)
- Automotive applications (to measure oil and coolant temperatures in cars & trucks)
- Household appliances (like microwaves, fridges, and ovens)
- Circuit protection (i.e. [surge protection](#))
- Rechargeable [batteries](#) (ensure the correct battery temperature is maintained)
- To measure the thermal conductivity of [electrical materials](#)
- Useful in many basic electronic circuits (e.g. as part of a [beginner Arduino starter kit](#))
- Temperature compensation (i.e. maintain resistance to compensate for effects caused by changes in temperature in another part of the circuit)

Thermocouple or Thermoelectric Thermometer

- A **thermocouple** is an electrical device consisting of two dissimilar electrical conductors forming an electrical junction. A thermocouple produces a temperature-dependent voltage as a result of the thermoelectric effect or Seebeck-effect and this voltage can be interpreted to measure temperature. Thermocouples are a widely used type of temperature sensor.
- The amount of EMF generated in the thermocouple is very minute (millivolts), so very sensitive devices must be utilized for calculating the e.m.f produced in the circuit. The common devices used to calculate the e.m.f are voltage balancing potentiometer and the ordinary galvanometer. From these two, a balancing potentiometer is utilized physically or mechanically.

Thermocouple Working Principle

See beek-effect:

- This type of effect occurs among two dissimilar metals. When the heat offers to any one of the metal wire junction, then the flow of electrons supplies from hot metal wire junction to cold metal wire junction. Therefore, direct current stimulates in the circuit.

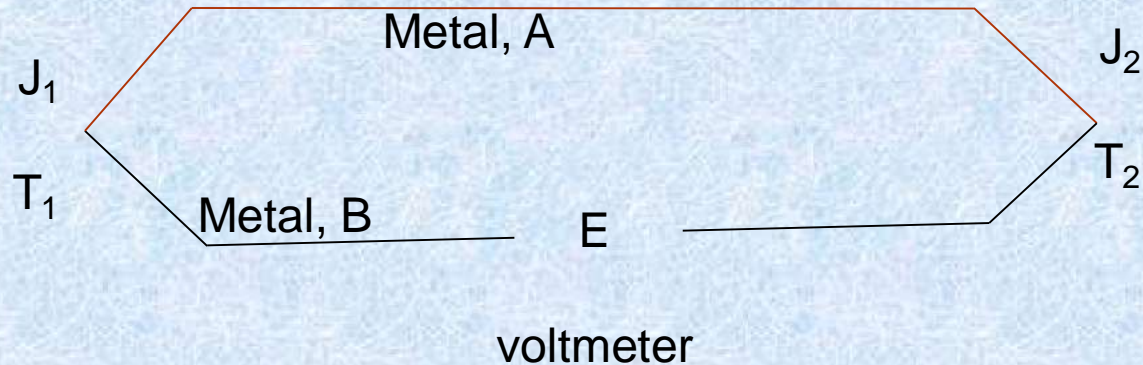

Construction & Working of Thermocouple

- The thermocouple schematic diagram is shown in the below figure. This circuit can be built with two different metals, and that are coupled together by generating two junctions. The two metals are surrounded by the connection through welding.

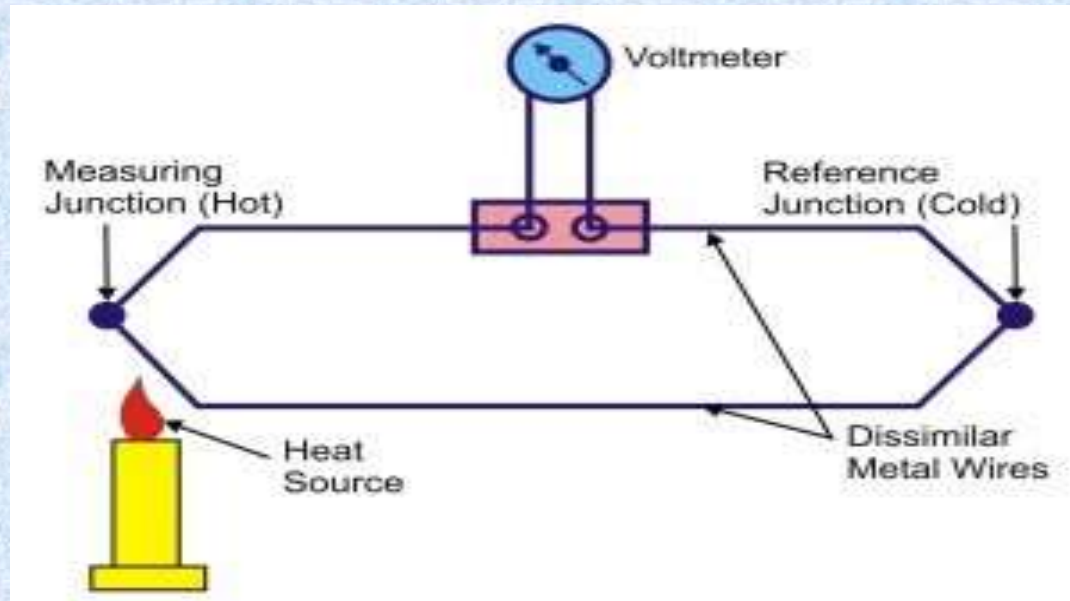

- In the above diagram, the junctions are denoted by measuring junction (Hot) & Reference junction (Cold) and the temperatures are denoted by say T_1 & T_2 . When the temperature of the junction is dissimilar from each other, then the electromagnetic force generates in the circuit.

- If the temperature at the junction end turns into equivalent, then the equivalent, as well as reverse electromagnetic force, produces in the circuit, and there is no flow of current through it. Similarly, the temperature at the junction end becomes imbalanced and then the potential variation induces in this circuit.

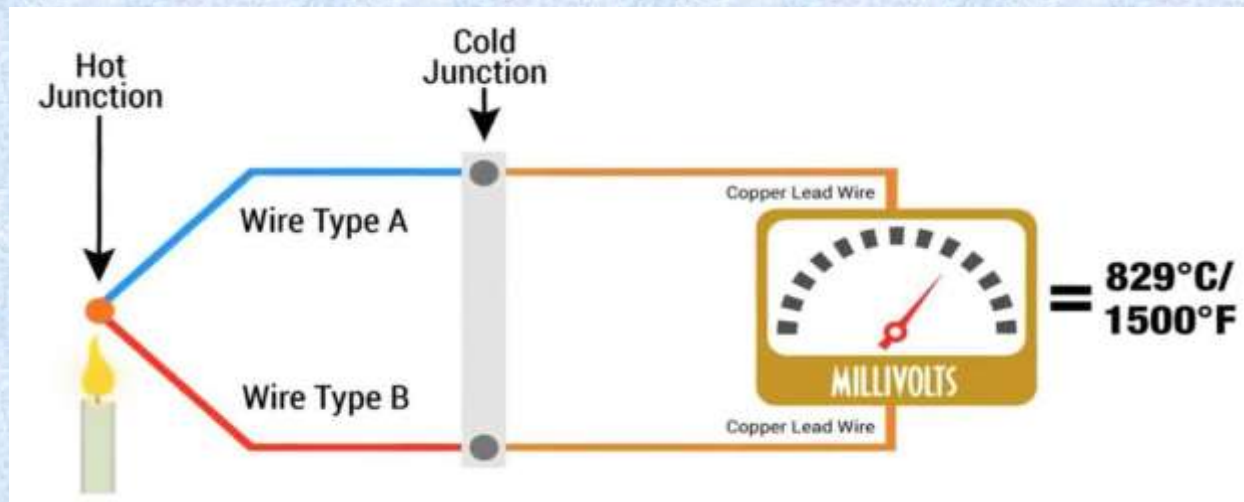

- The magnitude of the electromagnetic force induced in the circuit relies on the sorts of material utilized for thermocouple making. The entire flow of current throughout the circuit is calculated by the measuring tools.

Law of intermediate Temperatures & intermediate Metals

Law of intermediate Temperatures:

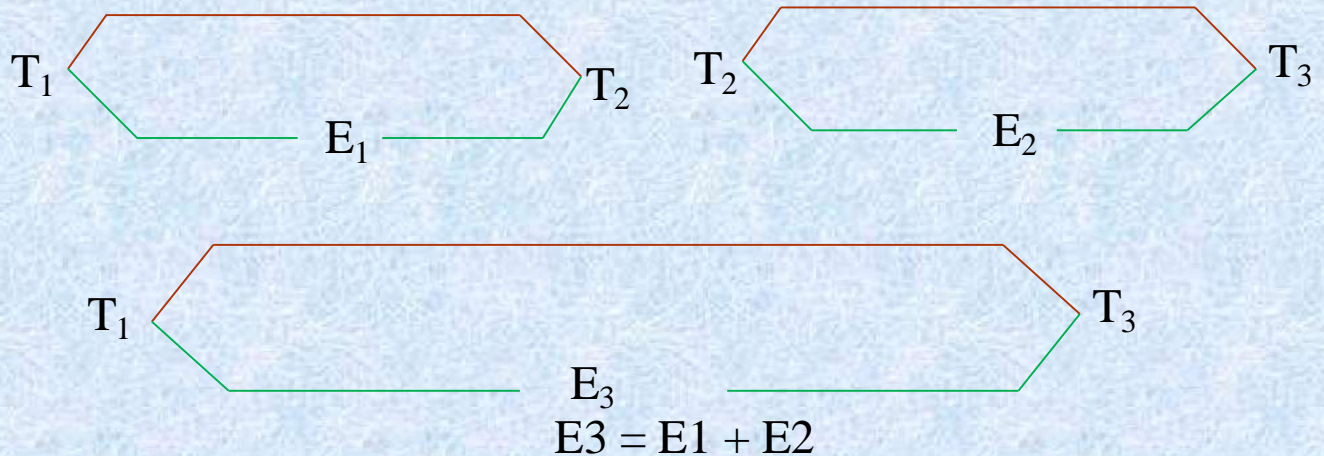

Law of intermediate Metals:

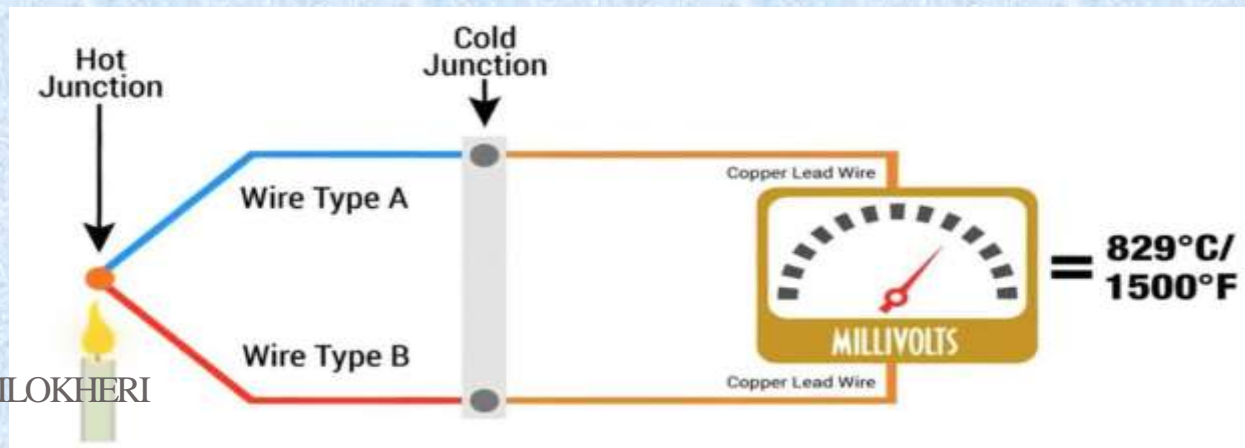

Characteristics of some thermocouples

S. No.	Type	Thermocouples Material	Approximate sensitivity ($\mu\text{V}/^\circ\text{C}$)	Useful temperature range ($^\circ\text{C}$)
1	T	Copper-Constantan	20-60	-180 to +400
2	J	Iron-Constantan	45-55	-180 to +850
3	K	Chromel-Alumel	40-55	-200 to +1300
4	E	Chromel-Constantan	55-80	-180 to +850
5	S	Platinum-Platinum/10%Rhodium	5-12	0 to +1400
6	R	Platinum-Platinum/13%Rhodium	5-12	0 to +1600
7	B	Platinum/30%Rhodium-Platinum/6%Rhodium	5-12	+100 to +1800
8	W5	Tungsten/5%Rhenium-Tungsten/20%Rhenium	5-12	0 to +3000

*Constantan=Copper/Nickel, Chromel=Chromium/Nickel, Alumel = Aluminium/Nickel

Advantages

- Accuracy is high.
- It is Robust and can be used in environments like harsh as well as high vibration.
- The thermal reaction is fast.
- The output signal is electrical and can be used for indicating, recording or microprocessor based control system.
- Wide operating temperature range i.e. from -200 to 3000 °C.
- Cost is low and extremely consistent

Disadvantages

- Nonlinearity
- Accuracy is less than RTD
- Low output voltage i.e. requires amplification in most of the applications.
- Need periodical checking or recalibration
- They requires insulation covering while using them in the conducting fluids.

Thermocouple Applications

- Measurement of surface temperature.
- Suitable for indicating of rapidly changing temperature.
- Thermocouples are used as a heat pump for performing thermoelectric cooling.
- These are used to test temperature in the chemical plants, petroleum plants.
- These are used in gas machines for detecting the pilot flame.

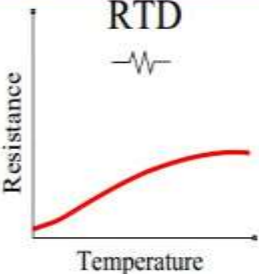
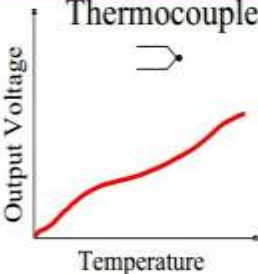
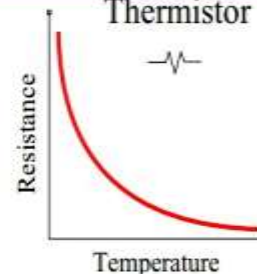
 <p>RTD</p>	 <p>Thermocouple</p>	 <p>Thermistor</p>	Output Characteristics
<ul style="list-style-type: none"> • Most accurate • Best stability • Higher linearity • Best interchangeability • Wide temperature range 	<ul style="list-style-type: none"> • Largest variety of styles • Self-powered • Rugged • Largest temperature range • Small size / fast response 	<ul style="list-style-type: none"> • High resistance values • Large resistance change • Two wire ohms measurement • Low sensor cost • Small size / fast response 	Advantages
<ul style="list-style-type: none"> • Current source required • Smaller resistance change • Low absolute resistance • Self heating • Higher sensor cost 	<ul style="list-style-type: none"> • Lowest stability • Low voltage output • Nonlinear • Cold junction reference needed • Lowest sensitivity 	<ul style="list-style-type: none"> • Limited temperature range • Current source required • Nonlinear • Self heating • Fragile 	Disadvantages
-260 to 850° C	-200 to 3000° C	-80 to 300° C	Temperature Range

Pyrometer

- When temperatures being measured are very high and **physical contact** with the medium to be measured **is impossible** or impractical then the **process used to measure that high temperature is called Pyrometry and the instruments are called Pyrometer.**
- These pyrometers are used under conditions where corrosive vapours or liquids would destroy thermocouples, resistance thermometers and thermistors if made to come in contact with the measured medium.
- These pyrometers find applications for temperatures which are above the range of thermocouples and also for rapidly moving objects.
- **Two type of pyrometer are thermal radiation pyrometer and optical pyrometers are used.**

Black body radiation

- **Black body radiation:** A body at higher temperatures emits electromagnetic radiation. The rate at which energy is emitted depends on surface temperature and surface conditions. The thermal radiation from a body is composed of wavelengths forming an energy distribution.
- The total emissive power of a black body e_b at a particular temperature is
- $e_b = \sigma T^4$
- In which σ is Stefan's Boltzmann constant and its value is $5.67 \times 10^{-8} \text{ W m}^{-2} \text{ K}^{-4}$

Principles of radiation pyrometer

- It measures the object's temperature by sensing the heat/radiation emitted from the object without making contact with the object.
- Radiation pyrometry measures the radiant heat emitted or reflected by a hot object.
- The radiation pyrometers operate on the principle that the energy radiated from a hot body is a function of its temperature.
- According to Stefan Boltzmann law, the heat radiated per square metre from body is:
$$E = \sigma (T^4 - T_0^4)$$

where –

σ = Stefan's Boltzmann constant

T^4 = Absolute temperature of hot body

T_0^4 = Absolute temperature of surrounding.

Total radiation pyrometer

- A radiation pyrometer consists of optical component to collect the radiation energy emitted by the object, a radiation detector that converts radiant energy into an electrical signal, and an indicator to read the measurements.
- Thermal detectors are used as sensors. Their hot junction is the radiation sensing surface. Thermopiles/Thermocouples can detect radiation of all wavelengths.
- A thermopile consists of a group of very small thermocouples so connected in series that their emfs are additive. This gives an increased sensitivity.

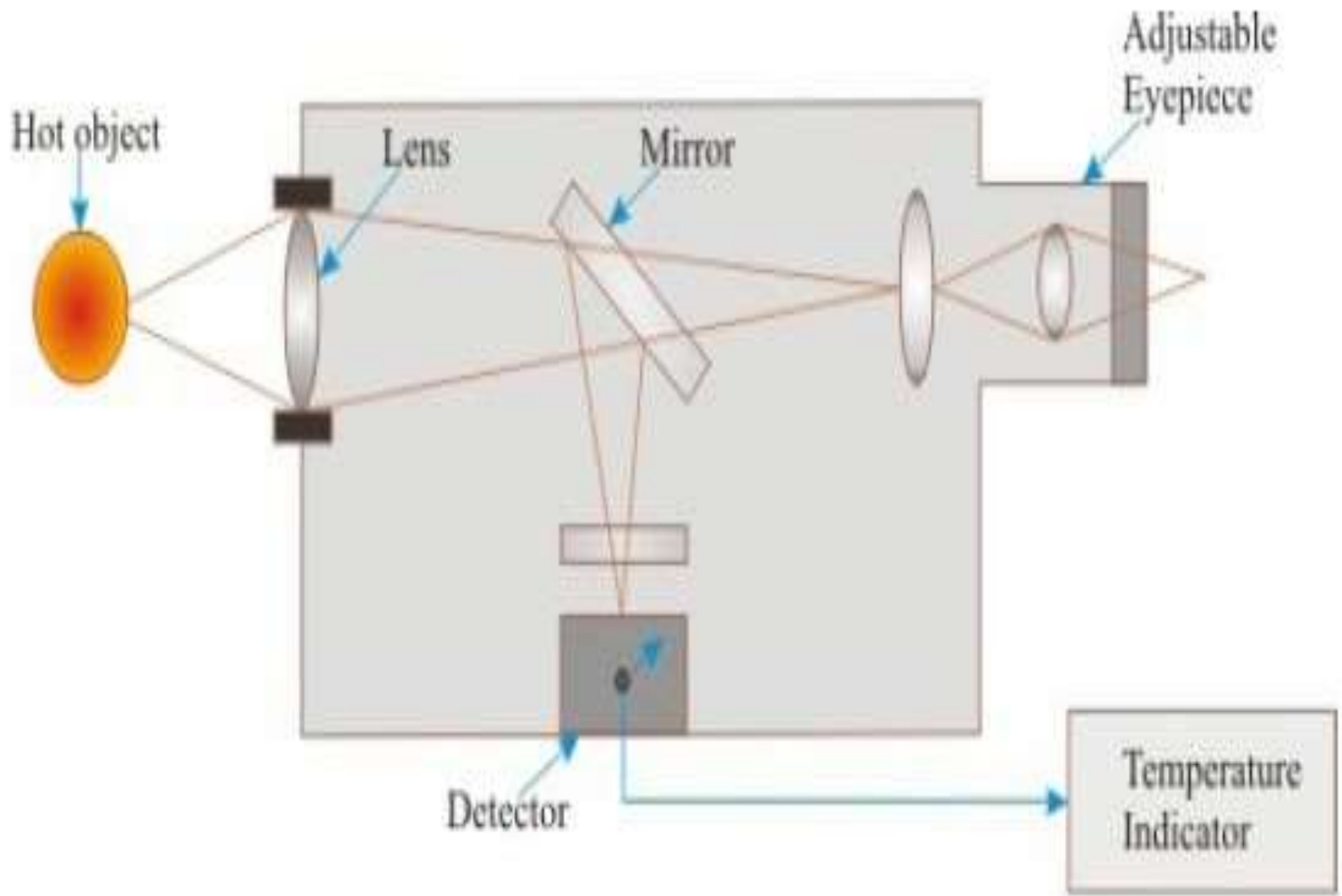

Thermopile

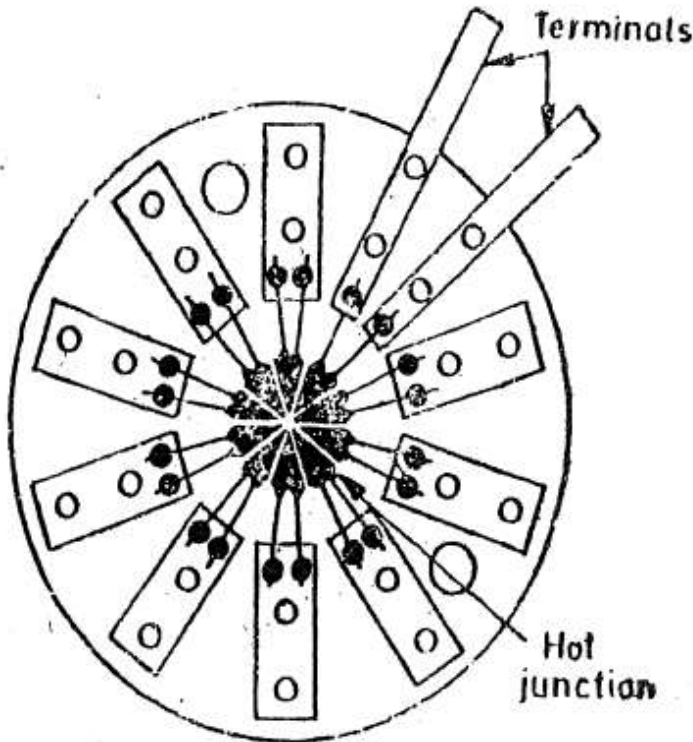
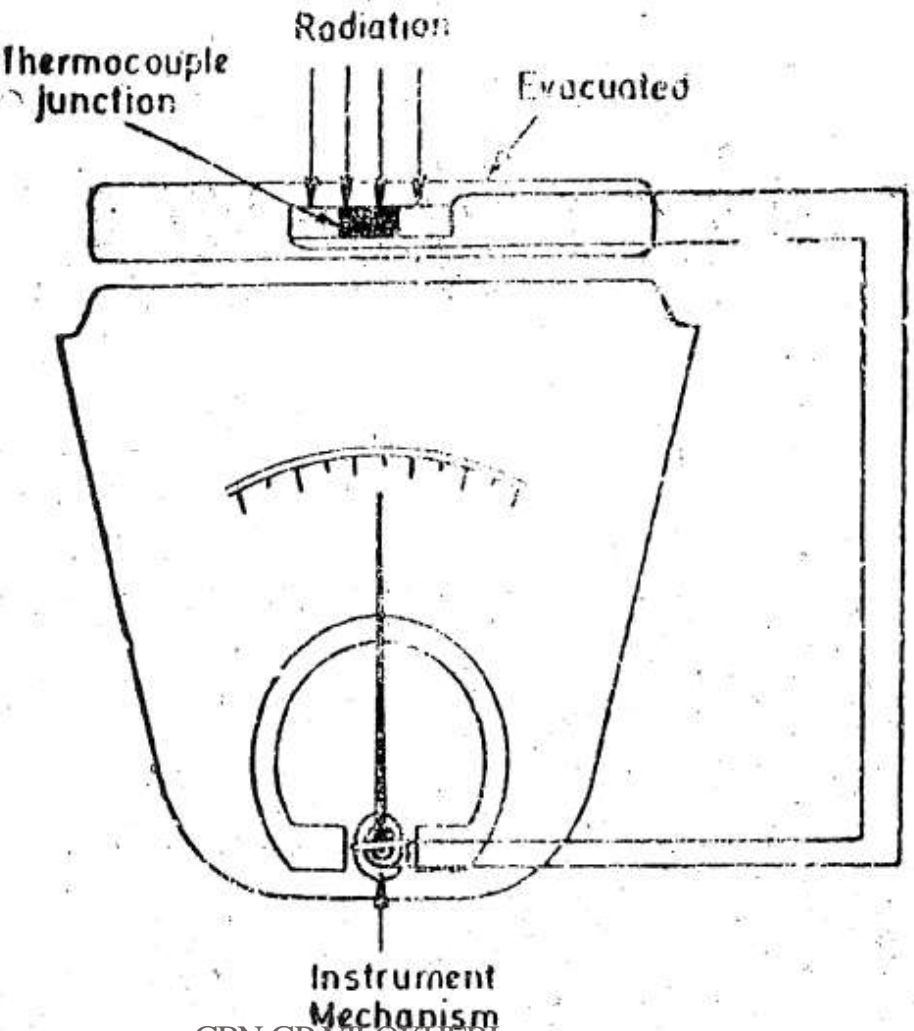

Limitations of Radiation Pyrometer

- Availability of optical materials limit on the wavelengths that can be measured.
- The surface of the hot object should be clean. It should not be oxidized. Scale formation does not allow to measure radiation accurately.
- Emissivity correction is required. Change in emissivity with temperature need to be considered.

optical pyrometer

- The optical pyrometer is designed to respond narrow band of wavelengths that fall within the visible range of the electro-magnetic spectrum.
- In this type of pyrometer, the tungsten filament of an electric bulb is used as a radiator. Figure shows an optical pyrometer.

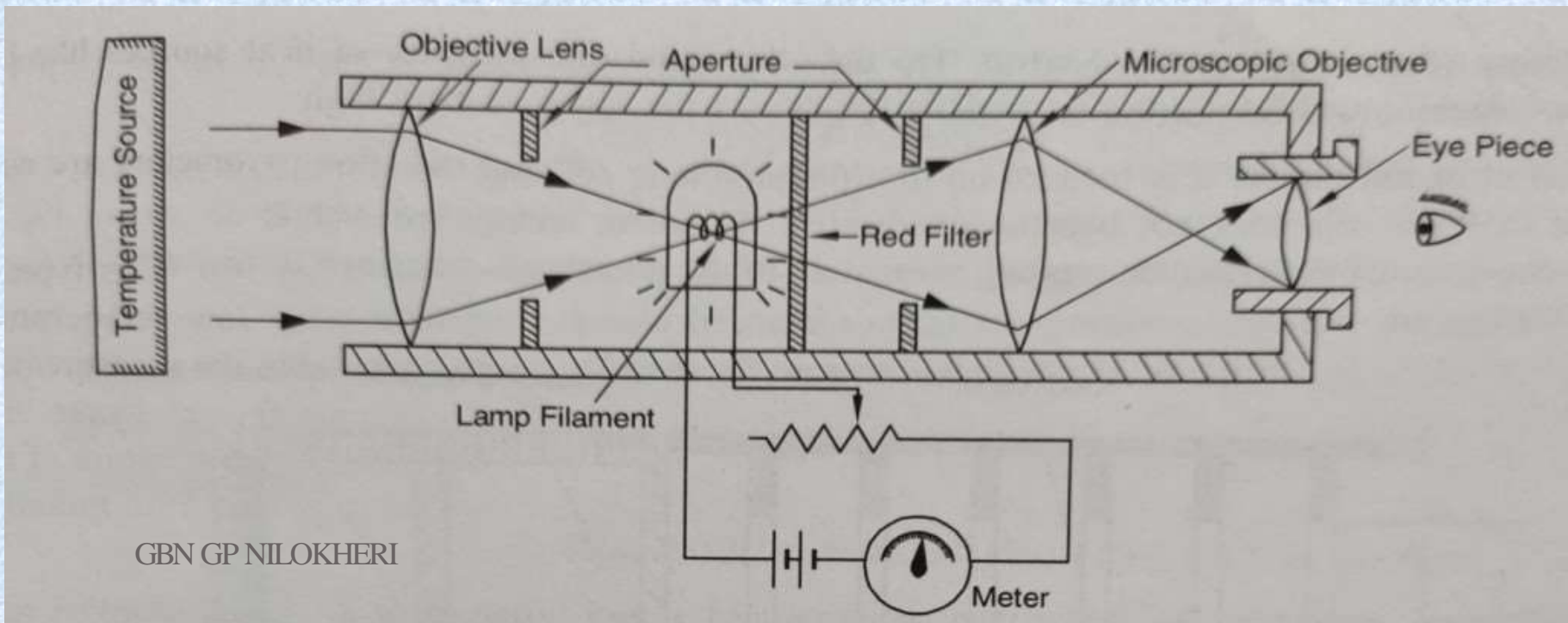

- The radiations from the source are focused onto the filament of the reference temperature using an objective lens.
- Now the eye piece is adjusted to focus the images the hot source and the filament.
- The intensity of radiation of filament is compared with the intensity of the radiation of the hot surface.

Now the lamp current is controlled such that filament •
appears dark if it is cooler than the source.
The filament will appear bright if it is hotter than source •
and
When both intensity match, the filament disappears •
against the back ground.

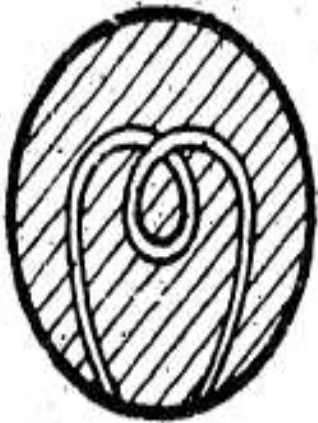

(a)

Filament too bright

GBN GP NILOKHERI

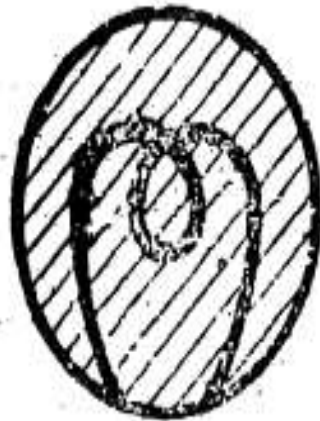

(b)

Filament too dark

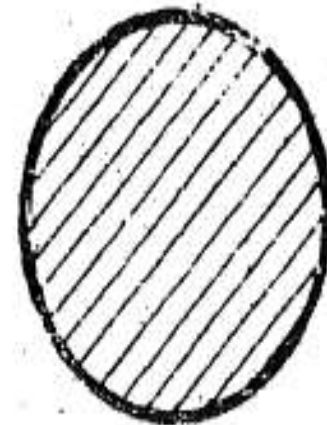

(c)

Equal brightness

- The intensity of the filament can be controlled by the current flowing through it.
- The ampere meter in the lamp circuit is calibrated in degree centigrade.
- The maximum temperature of the filament is $2800-3000^{\circ}\text{C}$ at the rated voltage.
- The minimum visible radiation is at 600°C . Hence we can measure the temperature in between $600 - 3000^{\circ}\text{C}$
- This optical pyrometer is widely used for accurate measurement of temperature of furnaces, molten metals and other heated materials.

Measurement of Humidity

- **Humidity:-** Humidity is the measure of water vapour present in a air or gas. It is usually measured as absolute humidity, relative humidity or dew point temperature.
- **Absolute Humidity:-** It is the mass of water vapour present per unit volume. (units are grams of water vapor per cubic meter volume of air).
- **Relative Humidity:-** It is the ratio of water vapour pressure actually present to water vapour pressure required for saturation at a given temperature. The ratio is expressed in percent.

- **Specific Humidity:-** It is the ratio of weight of vapour per unit of mixture.
- **Moisture:-** Moisture is the term used for water that is absorbed or bound into any material.
- **Dew Point:-** The dew point is the temperature at which the saturation water vapour pressure is equal to the partial pressure of the water vapour (in the atmosphere).

Relative humidity (RH) is always dependent upon temperature.

Relative Humidity

The most commonly used measure of humidity is relative humidity. Relative humidity can be simply defined as the amount of water in the air relative to the saturation amount the air can hold at a given temperature multiplied by 100. Air with a relative humidity of 50% contains a half of the water vapour it could hold at a particular temperature.

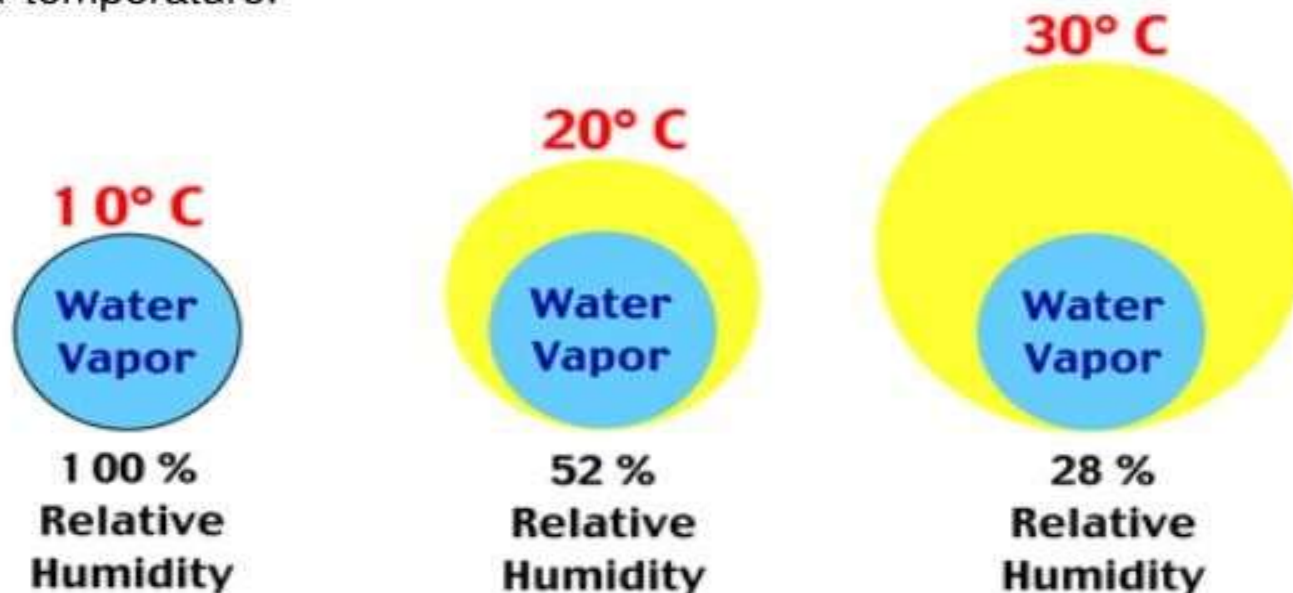

Hygrometers

- A hygrometer measures the value of humidity directly. Or
- Hygrometer is an instrument which gives a direct indication of amount of moisture in air or other gas. Generally,
- The output of a Hygrometer is used to indicate relative humidity.

Type of Hygrometer

- Several materials exhibit changes in electrical properties that are caused by humidity. According to that changes in electrical properties there are following types of hygrometer which are used to measure humidity/relative humidity directly.
 1. Resistive Hygrometer.
 2. Capacitive Hygrometer.
 3. Microwave Refractometer.
 4. Aluminium Oxide Hygrometer.
 5. Crystal Hygrometer.

Resistive Hygrometer

- The conducting film of the resistive hygrometer is made by the lithium chloride and the carbon.
- resistance changes cover a wide range, e.g. 10^4 to $10^9 \Omega$ as the humidity changes from 100 to 0 per cent.
- The conducting film places between the metal electrodes. The resistance of the conducting film varies with the change in the value of humidity present in the surrounding air.

- The moisture absorbed by the lithium chloride will depend on the relative humidity. If the relative humidity is high, the lithium chloride will absorb more moisture and their resistance decreases.

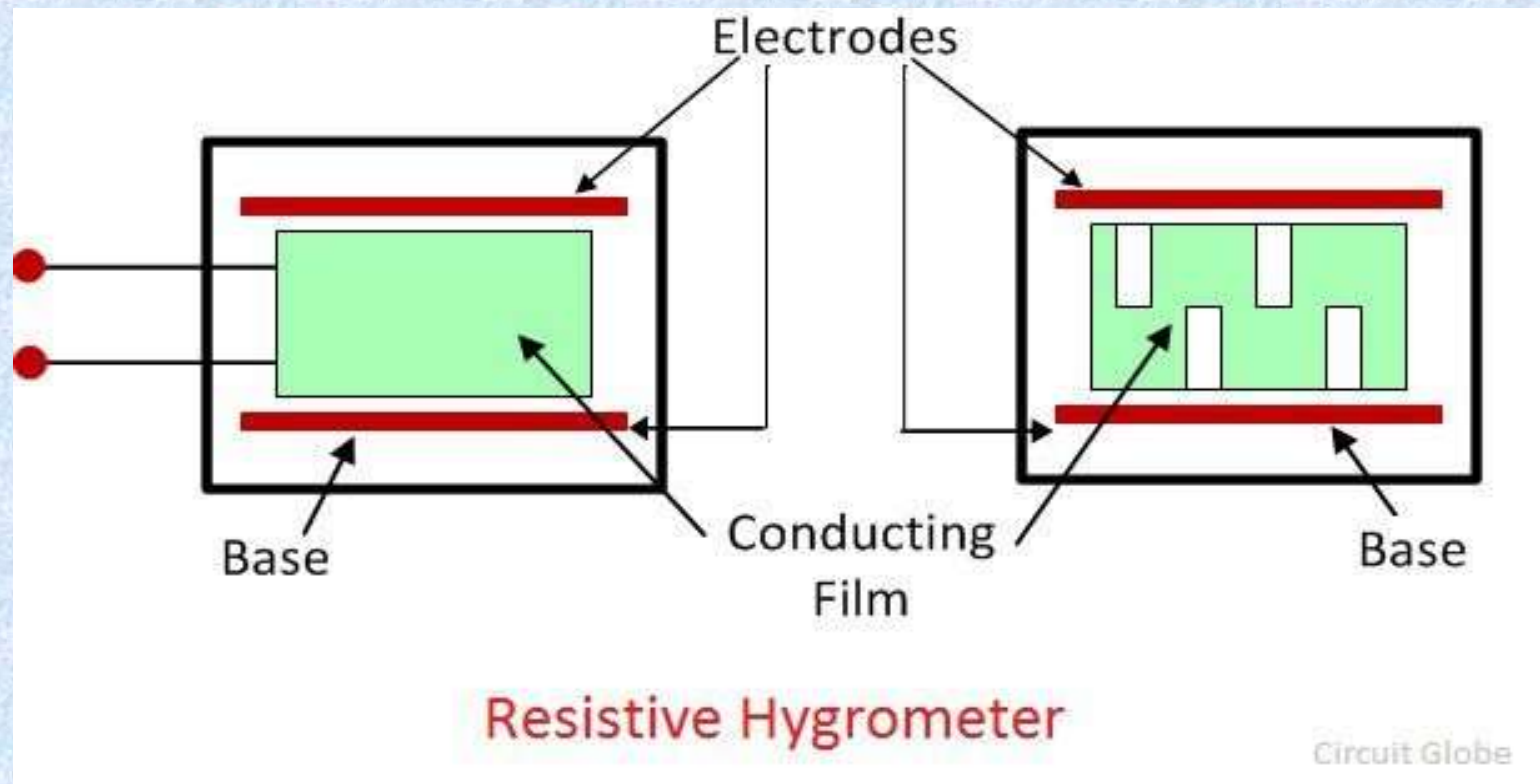

- Resistance is measured either with a Wheatstone bridge or by a combination of current and voltage measurements.
- The change in the value of resistance is measured by applying the alternating current to the bridge.
- The direct current is not used in the bridge as they breakdowns the layer of lithium chloride.
- The obstructions occur in the flows of current shows the value of resistance or the value of relative humidity.

Capacitive Hygrometer

- Some hygroscopic materials exhibit a change in dielectric constant with humidity changes.
- In addition, the presence of water Vapour in air changes the dielectric constant of the mixture.
- In either case, the changes are small; and the change in capacitance is usually measured by including it as the frequency-determining element in an oscillator, heterodyning this signal with a beat frequency oscillator, and measuring the resulting difference frequency.
- These transducers have response time of about 1 s.

Microwave Refractometer

- For secondary standards, a system consisting of two cavities each of which is coupled to a klystron, may be employed.
- One cavity contains dry air, the other contains the mixture to be measured.
- The change in dielectric constant changes the frequency of one oscillator.
- This difference is measured electronically.
- The complexity of the devices precludes their use except in very special situations.

Aluminium Oxide Hygrometer

- In this hygrometer, the aluminium oxide is coated with the anodized aluminium.
- The dielectric constant and the resistance of the aluminium changes by the effects of the humidity.
- The aluminium oxide hygrometer uses the aluminium as their one electrode and very thin gold layer as the second electrode.

- This thin electrode is porous for absorbing the air vapour mixture. The changes occur in the capacitance and resistance of the material because of the humidity. The change in properties changes the impedances of the material. The impedance measures with the help of the bridge. This hygrometer is the essential component of the electronic system.

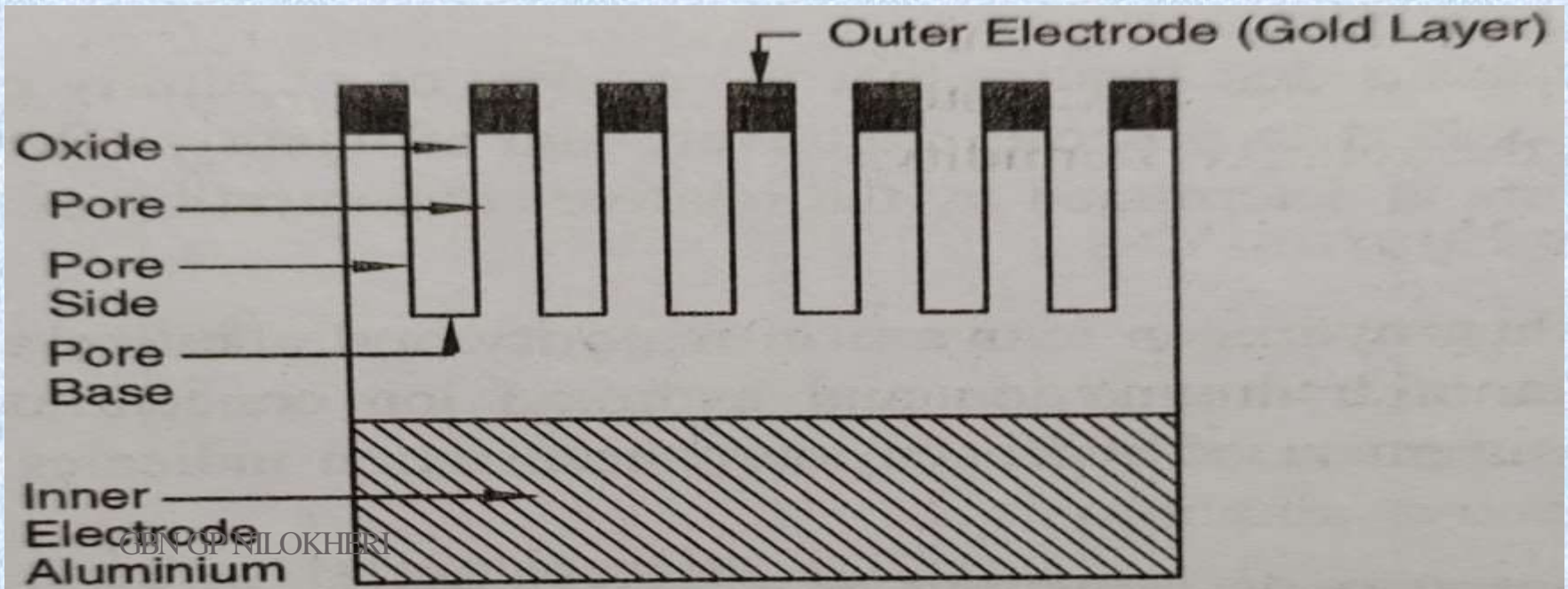

Crystal Hygrometer

- Some crystals are hygroscopic and others may be coated with a hygroscopic material.
- The coating materials are hygroscopic polymers.
- The crystals are used as frequency determination elements in electronic oscillators.
- Frequency shifts with humidity as the mass of the crystal changes with amount water absorbed by coating are measured electronically.
- These transducers are useful if a telemetry system is needed because the frequency range can be chosen as a standard telemetry frequency.

A crystal hygrometer using quartz

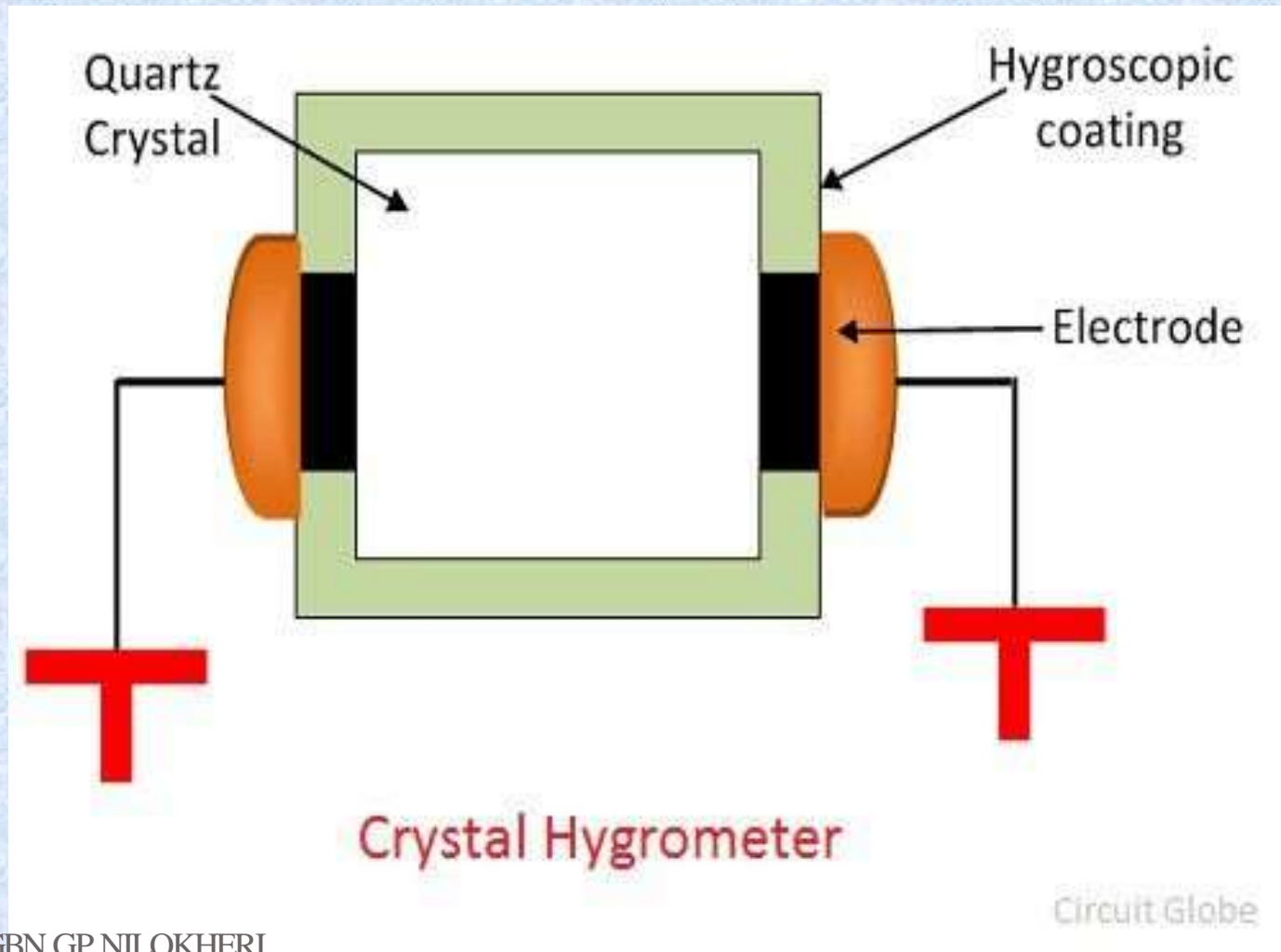

PH MEASUREMENT

pH Value

- The degree of alkalinity or acidity of aqueous solution is determined by the relative concentration of hydrogen and hydroxyl ions in solution.
- Solution is acidic when hydrogen ions are in majority and alkaline when hydroxyl ions are in majority .
- The dissociation constant is the product of hydrogen (H^+) ions and hydroxyl (OH^-) ions and this product is always equal to 10^{-14} .
- **Hydrogen ion concentration is measured on a scale known as pH scale.**
- **pH value of a solution is defined as the negative logarithm of the hydrogen ion concentration or**
 $pH = -\log_{10} (H^+)$.

- This pH scale ranges from 0 to 14.
- In a neutral solution, the concentrations of both hydrogen and hydroxyl ions are equal i.e., both are 10^{-7} . Therefore, a neutral solution : $\text{pH} = -\log(10^{-7}) = 7$, like pure water has a pH value of 7.

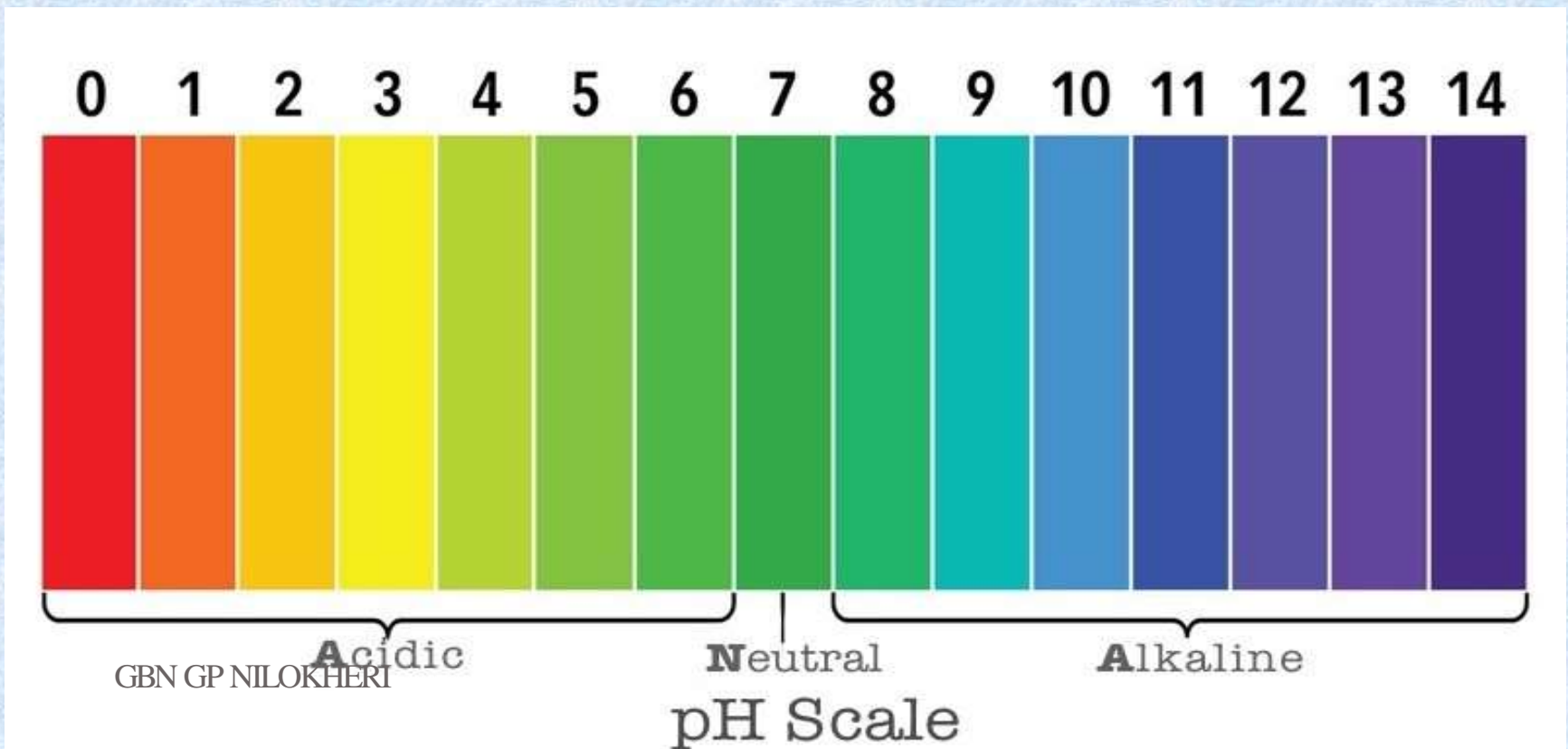

- Supposing the solution is acidic. Therefore the hydrogen ion concentration is more. Suppose it is 10^{-5} and therefore the hydroxyl ion concentration is 10^{-9} .
- The pH value for this solution is $\text{pH} = -\log_{10}(\text{H}^+)$
 $= -\log_{10}(10^{-5}) = 5$.
- Thus for acidic solutions the pH value lies between 0 to 7. In case of alkaline solution the pH value is between 7 to 14.
- For alkaline solutions the hydroxyl ion concentration is more. Supposing hydroxyl ion concentration is 10^{-2} and hence the hydrogen ion concentration is 10^{-12} .
- The pH value for this solution is: $\text{pH} = -\log_{10}(10^{-12}) = 12$.

pH Measurement

- The measurement of pH value is obtained by immersing a pair of electrodes into the solution to be measured and measuring the voltage developed across them.
- The action is somewhat similar to that of a voltaic cell where a pair of dissimilar electrodes are immersed into an electrolyte.
- In the pH cell, one of the electrodes called the **reference electrode**, is at a constant potential regardless of the pH value of the solution under test. The potential of the other electrode, called the **measuring electrode**, is determined by the pH value of the solution.
- Thus the potential difference between the two electrodes depends upon the pH value of the solution.

- The **reference electrode** is made of glass and consists of an inner assembly containing a solution of calomel (mercury chloride) and mercury.
- This assembly is surrounded by a larger glass tube, and the space between the two contains an accurate solution of potassium chloride (KCl).
- A tiny opening in the bottom of the electrode permits the potassium chloride to diffuse very slowly into the solution under test.
- In this way, electrical contact is made between this solution and the calomel solution of the electrode.

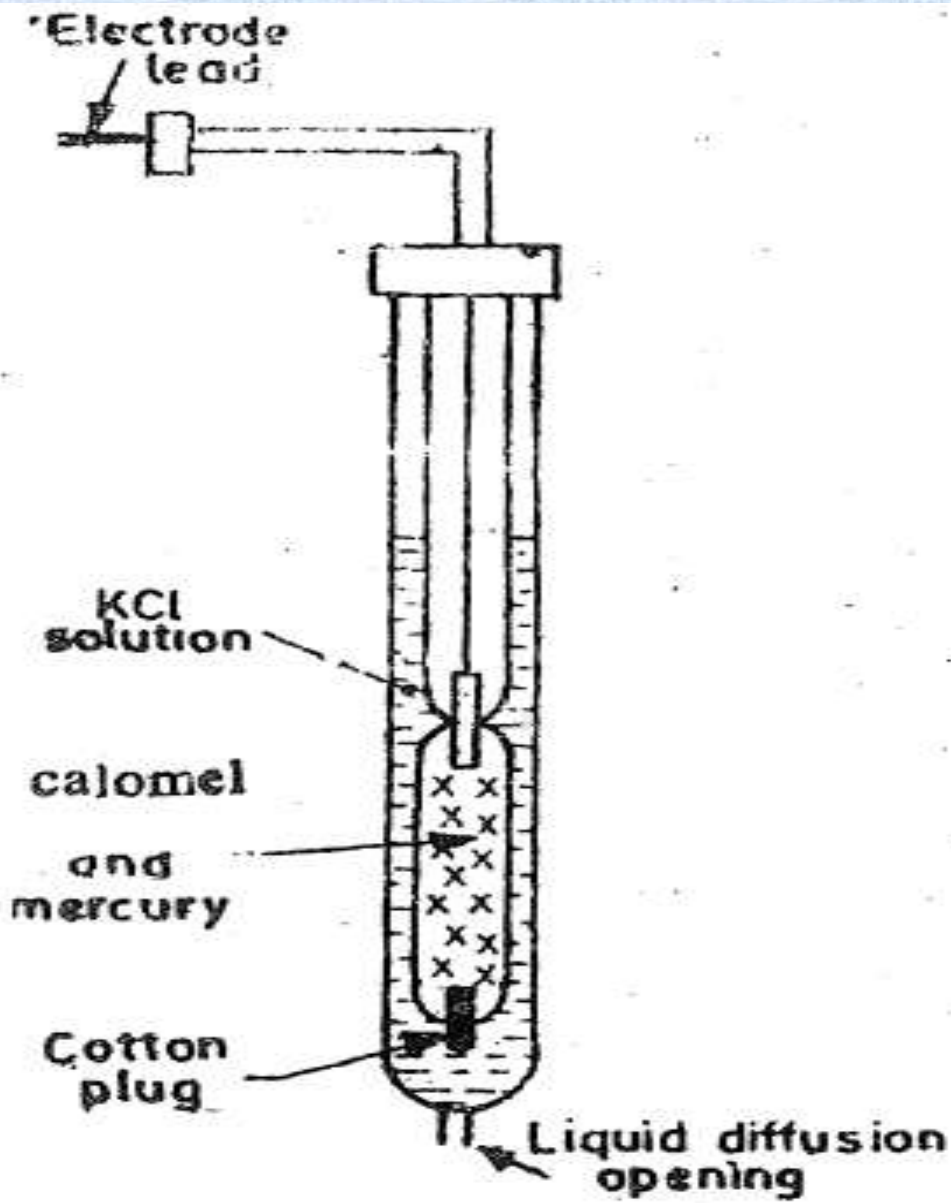

(a) Reference electrode.

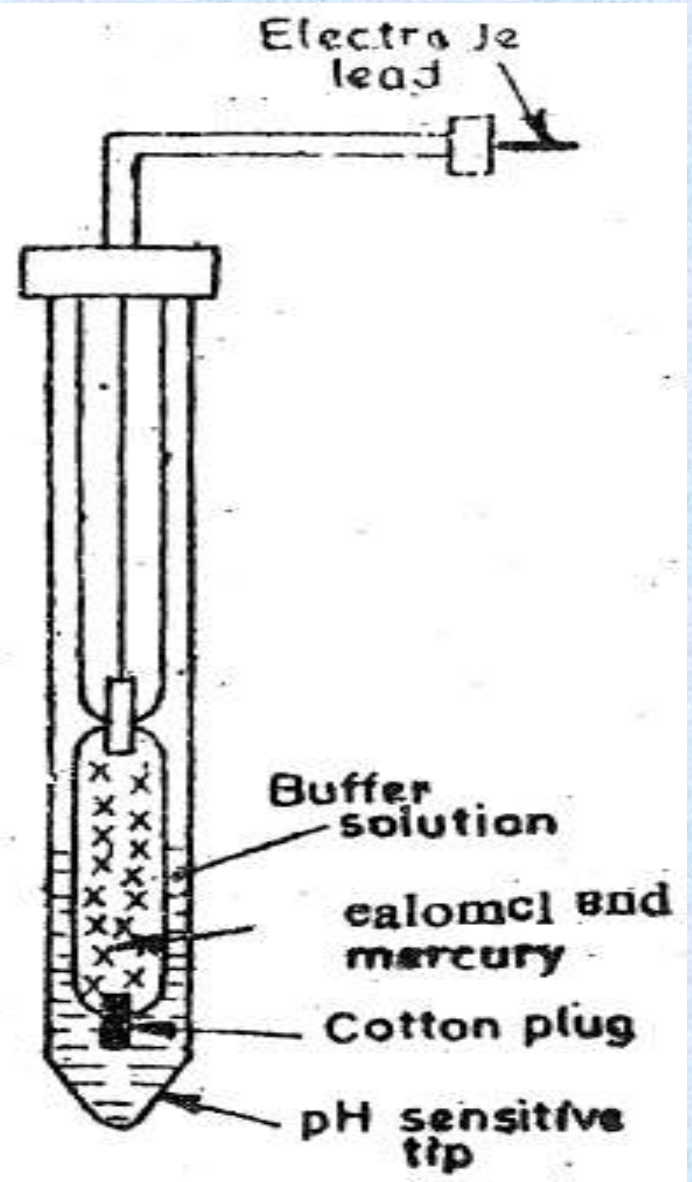

(b) Measuring electrode.

- The **measuring electrode** (also known as **the glass electrode**), the mercury calomel element is surrounded by a buffer solution of constant pH .
- The bottom of the outer tube has no opening.
- It tapers down to a tip made of thin glass of special composition.
- At this tip a potential difference is developed between the buffer solution and the solution under test because of the difference in the pH value of the two solutions.
- Since the pH value of the buffer solution is constant, the net potential of this electrode is a function of the pH value of the solution being tested.

ELECTRONIC METHOD OF pH MEASUREMENT

- In this type, pH value is read on a digital meter or indicating type meter.

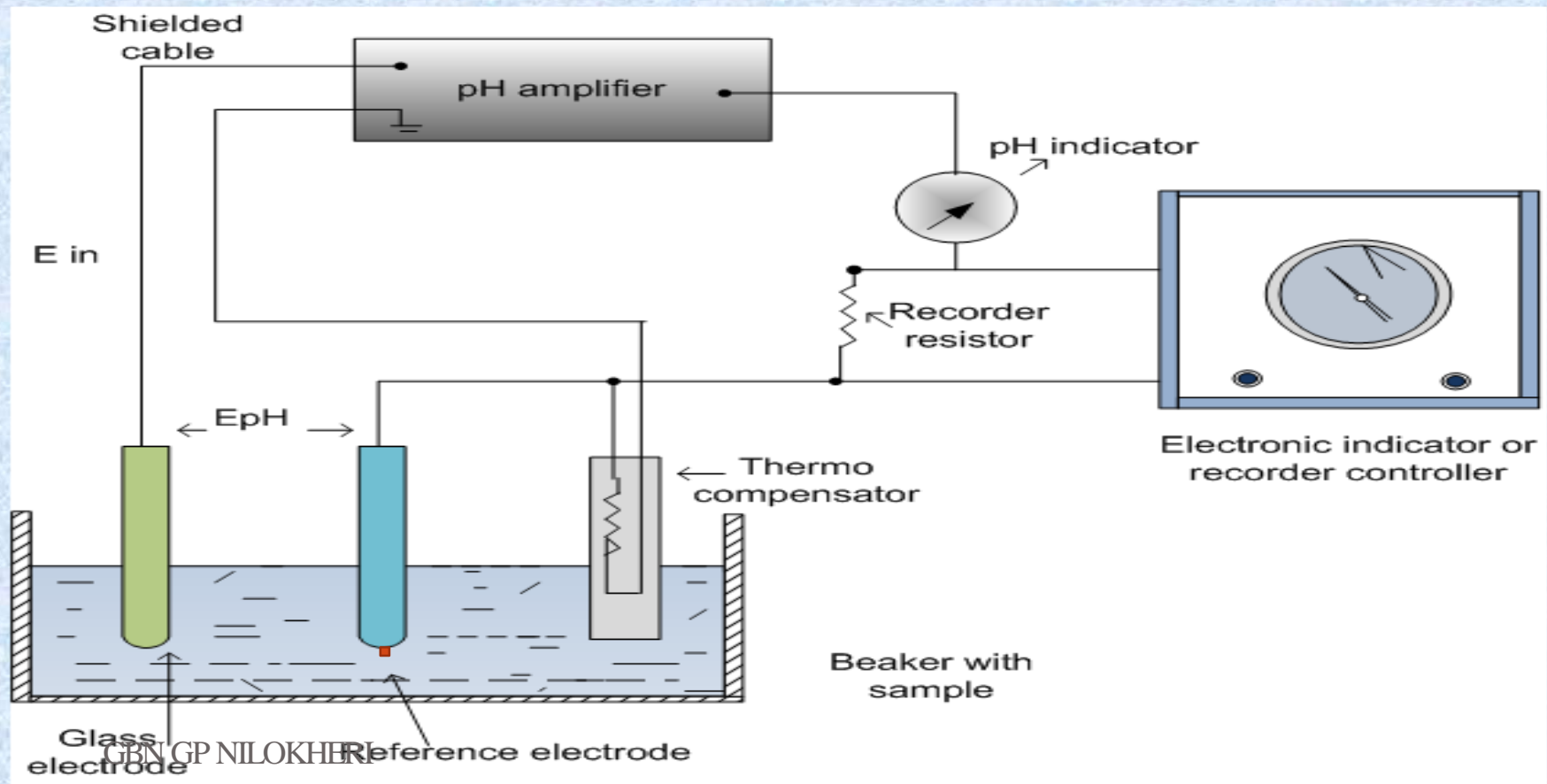

Circuit for electronic pH measurement

CPN GP NILOKHARI

Theory of ELECTRONIC METHOD

- In this method there are two electrodes, one as a Reference electrode and other is measuring electrode.
- The voltage difference between two is depend on the pH value of solution. The output voltage obtained here is not linear and is of very low value.
- A pH amplifier is used to amplify and line arise this voltage.
- The output of the amplifier can be sent to any indicating instrument or can be sent to recorder or to computer for storage.
- Thermo compensator is used to avoid the effect of temperature variation on pH value measurement.

Advantages of pH Measurement

- pH Measurement is inexpensive and robust.
- Pocket size pH Meters are user friendly.
- Readings are accurate and precise.

Disadvantages of pH Measurement

- Temperature impacts the output readings.
- pH Measurement using glass electrodes must be clean as deposition on the electrodes affects the readings.

Applications of pH Measurement

- pH Measurement is very crucial in Agriculture industry for soil evaluation. Major crops require alkaline environment and hence pH Measurement becomes necessary.
- It is also used in Food industry especially for dairy products like cheese, curds, yogurts, etc.
- It becomes mandatory for chemical and pharmaceutical industries.
- It becomes a significant factor in the production of detergents.
- pH level monitoring is essential in water treatment plants and RO water purifiers.

Level measurement

- Level measurement is important part in many processes like water treatment, chemical treatment, water handling and distribution etc.
- The direct conversion to liquid level position to electrical signal is used in many instances.
- The measurement is generally done by two conversions, so that the liquid level is determine indirectly.
- The first conversion usually is liquid level to a displacement through a float in a liquid or a spring loaded plate in contact with the surface in the case of granular solids.
- This displacement is then converted into an electrical signal by a secondary transducer connected to float or plate.

- Different types of transducers are used for level measurements:
 1. Resistive
 2. Inductive
 3. Capacitive
 4. Gamma Rays method
 5. Ultrasonic method
 6. Float type

Resistive Method

- This method uses mercury as a conductor and number of contact rods are placed at various liquid levels.
- As head h increases, the rising level of mercury above the datum, shorts successive resistors R and increases the value of current.
- The ammeter used may be calibrated to read the value of h directly.

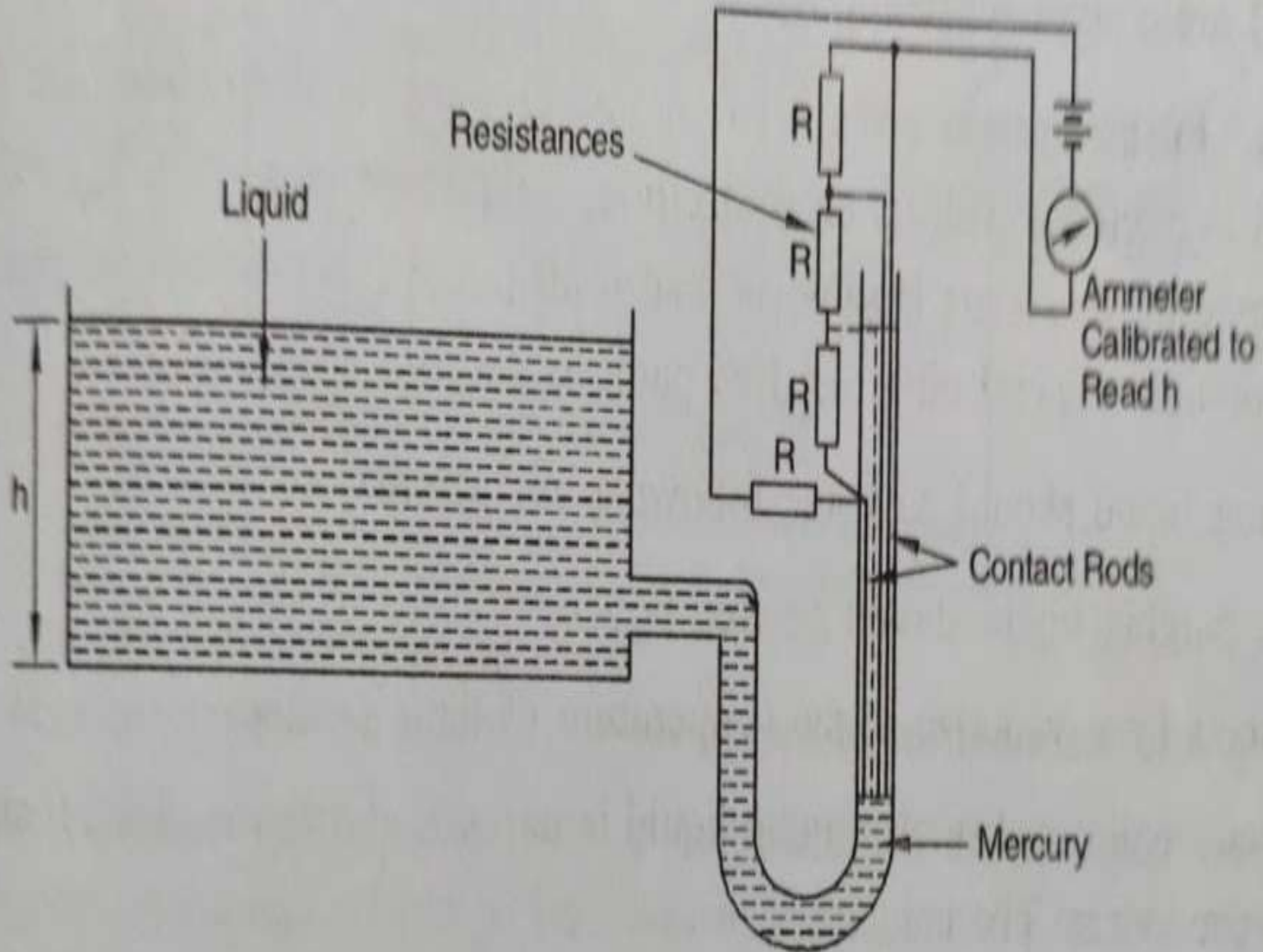

● Advantages

1. Where there is a need for a fairly continuous record of the level, more and more contact rods can be added, with separate signal outputs for each contact rod. The signal can be used for indication and also for initiating some control action to actuate the valves or pumps as well as warning lights and alarms depending upon the level.
2. The system uses low voltage to eliminate danger to the operators and to prevent arcing , at the contact points.
3. The signal can be transmitted to any desired point.
4. The unit is simple to calibrate since the distance between the levels of contact rods can be accurately measured and the indicated value may be checked for each measured value.

● Disadvantages

1. Due to arcing at the contact points, it is not safe to use this transducer in explosive atmosphere.
2. In order to have a stepless indication of the liquid level, an extremely large number of contact rods are needed.
3. The contact rods are corroded by corrosive liquids. In addition, the electric charges promote corrosion
4. These systems also present difficulties when there is saturated vapour above the liquid phase.
5. Any changes in the conductivity of the liquid causes serious errors.

Inductive Methods

- The inductive level transducers are mainly used for measurement of level of conductive liquids employing variable permeability method.
- In this arrangement uses two coils L_1 and L_2 wound around a steel tube containing the liquid.
- The coils are connected in series through a resistance and the circuit is energized by an alternating current source.
- The inductance of each coil is initially equal.
- One coil say L_1 acts as the search coil and it can be set at a predetermined level.
- The inductance of the search coil changes rapidly as the conducting liquid moves into the plane of the coil.

- The method works well because the tape material is weakly magnetic and the liquid metal is a conductor which allows eddy currents to flow in it. The relationship between the output voltage and the liquid level is essentially nonlinear.

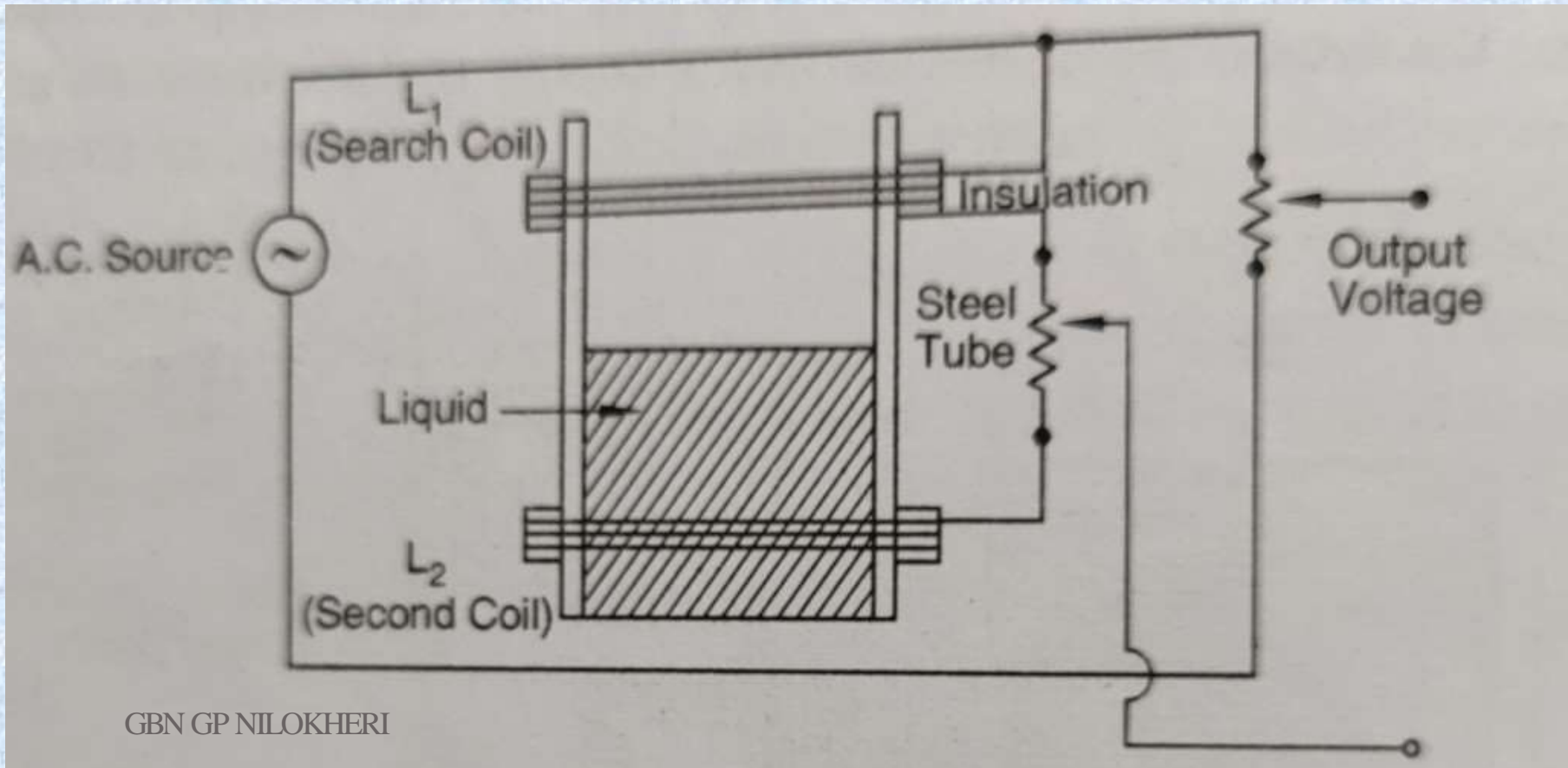

Capacitive Methods

- An insulated metal electrode firmly fixed near and parallel to the metal wall of the tank.
- If the liquid is non-conductive, the electrode and the tank wall form the plates of a parallel plate capacitor with the liquid in between them acting as the dielectric.
- If the liquid is conductive the rod and the liquid form the plates of the capacitor and the insulation between them is the dielectric.
- The capacitance of this capacitor depends, among other factors, upon the height of the dielectric between the plates.

- The greater the height, the greater the capacitance. The lesser the height, the smaller is the capacitance.
- Thus, the capacitance is proportional to the height of the liquid in the tank.

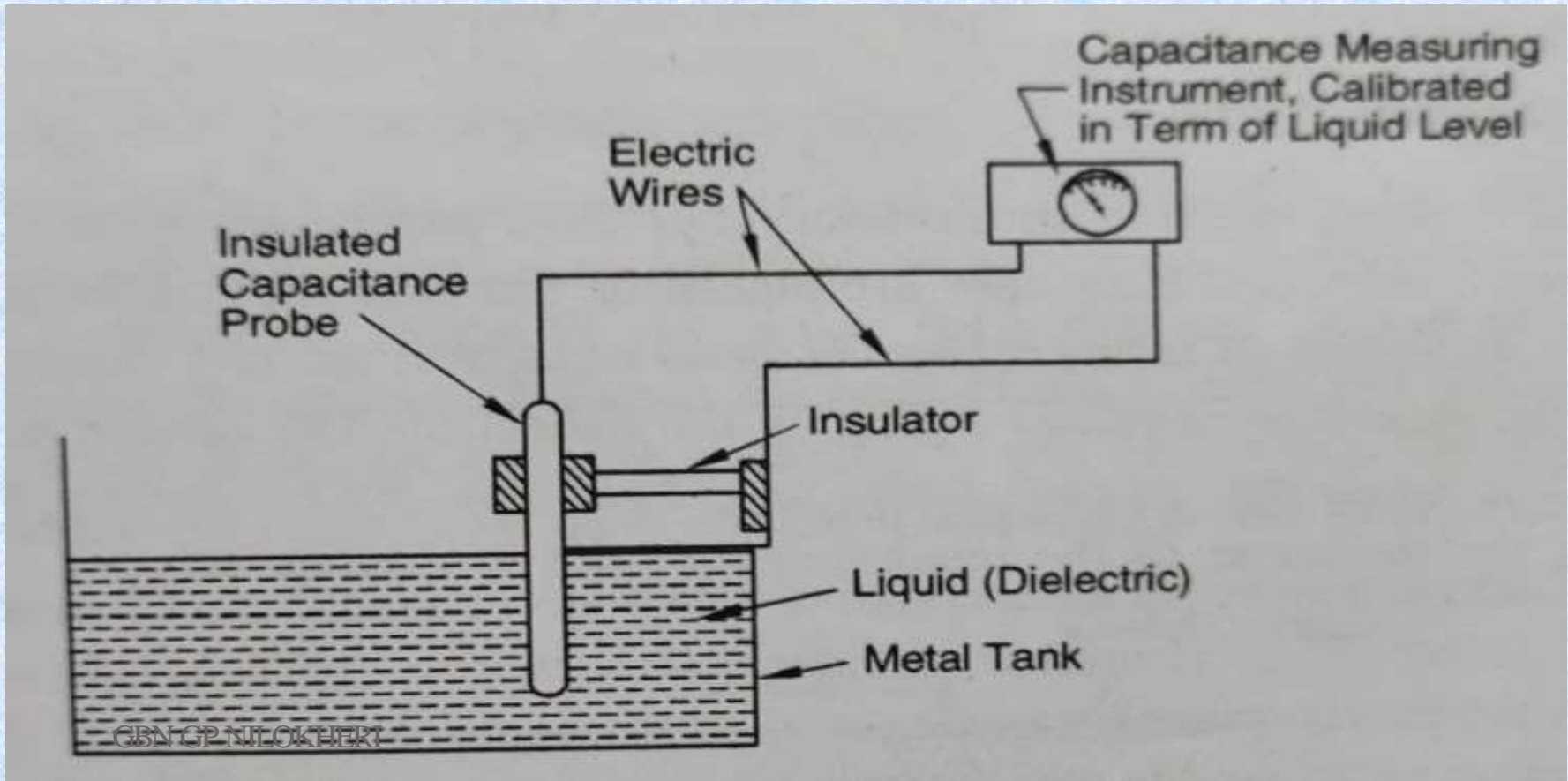

Gamma Rays method

- A source of gamma rays is placed at the bottom of the tank.
- A sensor of gamma rays like a Geiger Muller tube is placed outside the tank near the top.

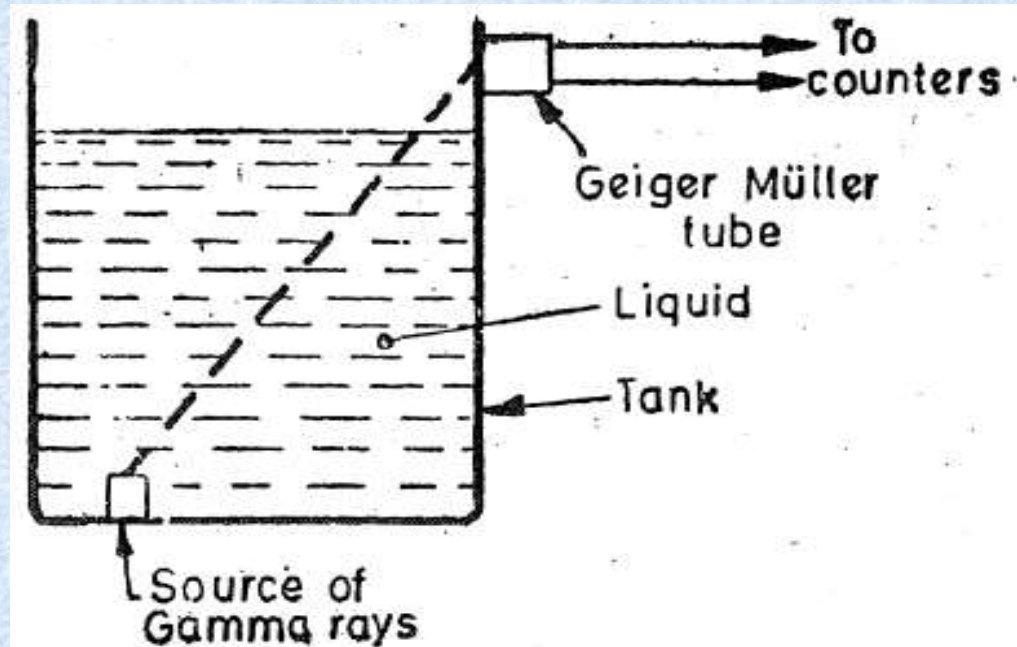

- As the gamma rays can penetrate the tank walls, the tube senses the rays and greater the intensity of other rays, the greater will be the output of this tube.
- Now the intensity of the rays will depend upon the liquid level.

- Maximum radiation will reach the Geiger Muller tube if the tank is empty.
- But if there is some liquid in it, some of the rays will be absorbed by the liquid and the radiations reaching the tube will be small, and hence its output is small.
- The higher the level of the liquid, the greater is the absorption and hence lesser will be the output of the Geiger Muller tube.
- Thus the output of the Geiger Muller tube is inversely proportional to the liquid level.
- The output of the Geiger Muller tube is in the form of pulses which may be counted by a counter.
- Thus the counter may be directly calibrated in terms of the liquid level.

Ultrasonic Method

- An ultrasonic transmitter receiver can be mounted on the top of tank for measurement of level of either solids or liquids.
- The beam is projected downwards by the transmitter and is reflected back by the surface of the solid or liquid contained in the tank.

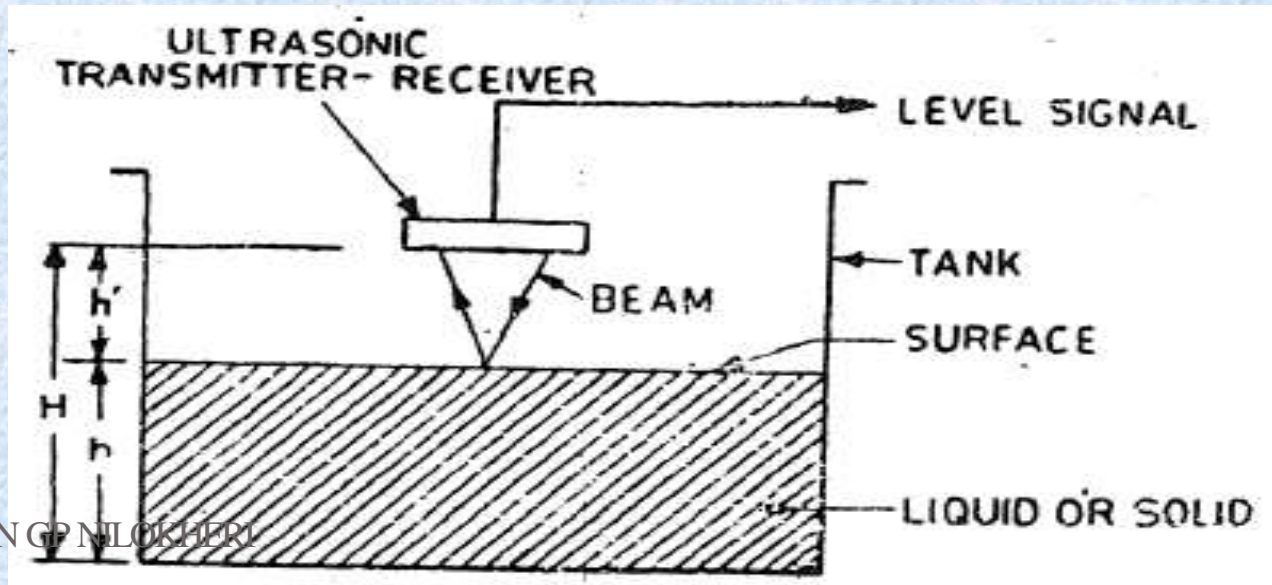

- The beam is received by the receiver.
- The time taken by the beam is a measure of the distance travelled by the beam.
- Therefore, the time 't' between transmitting and receiving a pressure pulse is proportional to the distance h' between the ultrasonic set and surface of the contents of the tank.

$$t \propto h' \propto (H-h)$$

- Since distance H between ultrasonic set and the bottom of the tank is fixed, time 't' is measure of level 'h'.

Float type

- A float operated voltage potential divider is shown in Fig.

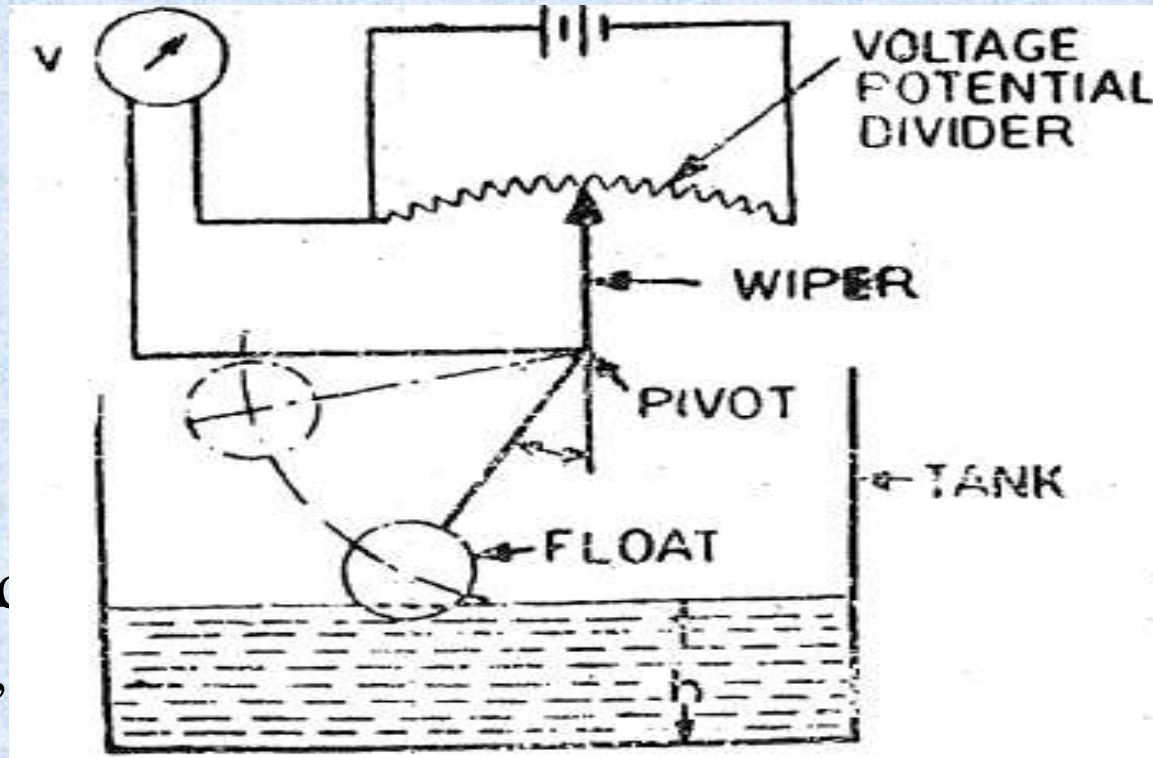

- As the liquid level in the tank rises, the float, which is a hollow ball, rises with it. This movement causes the wiper arm to slide along the potential divider, changing the output voltage.

rally a

- Its arm causes the wiper to move over the potential divider whose output terminals are connected to a voltmeter.
- As a float rises, a greater part the potential divider is included in the output circuit giving an increased output voltage.
∴ The output voltage V is proportional to the liquid level h .
- The output terminals from the potential divider may also be taken to a remote location for display and control.

Necessity for Measurement of Vibrations

- Many a times, it is require that the equipment should withstand stated levels of vibrations.
- This can be done quantitatively only through vibration measurements.
- Vibration measurements are frequently carried out on rotating and reciprocating machinery for analysis, design and trouble-shooting purposes.
- Vibration monitoring is carried out on such important machines as power station turbines and generators.
- It give an early warning of impending conditions which may develop and lead to complete failure and destruction of the equipment.

Nature of Vibrations

- Most vibrations are sinusoidal displacement of the vibrating member about its mean position.
- Such vibration is defined by its amplitude and frequency.
- For a sinusoidal vibration, the displacement is given by: $x = A \sin \omega t$.
- where A =amplitude, ω -angular frequency; rad/s.
- A sinusoidal vibration can be defined by giving its frequency plus its amplitude or maximum velocity or maximum acceleration.

Quantities measured in a vibrating system

1. Displacement
2. Velocity
3. Acceleration
4. Frequencies

- Displacement, velocity and acceleration are related to each other.
- If one of the three variables concerned (displacement, velocity or acceleration) is measured it is possible to determine the other two by integration or differentiation using electronic devices.
- The output of this transducer, after necessary signal conditioning is fed to the display which indicates or records the original measured variable or another variable derived from it.

Seismic Transducer

- The mass is connected through a parallel spring and damper arrangement to a housing frame.
- The housing frame is connected to the source of vibrations whose characteristics are to be measured.

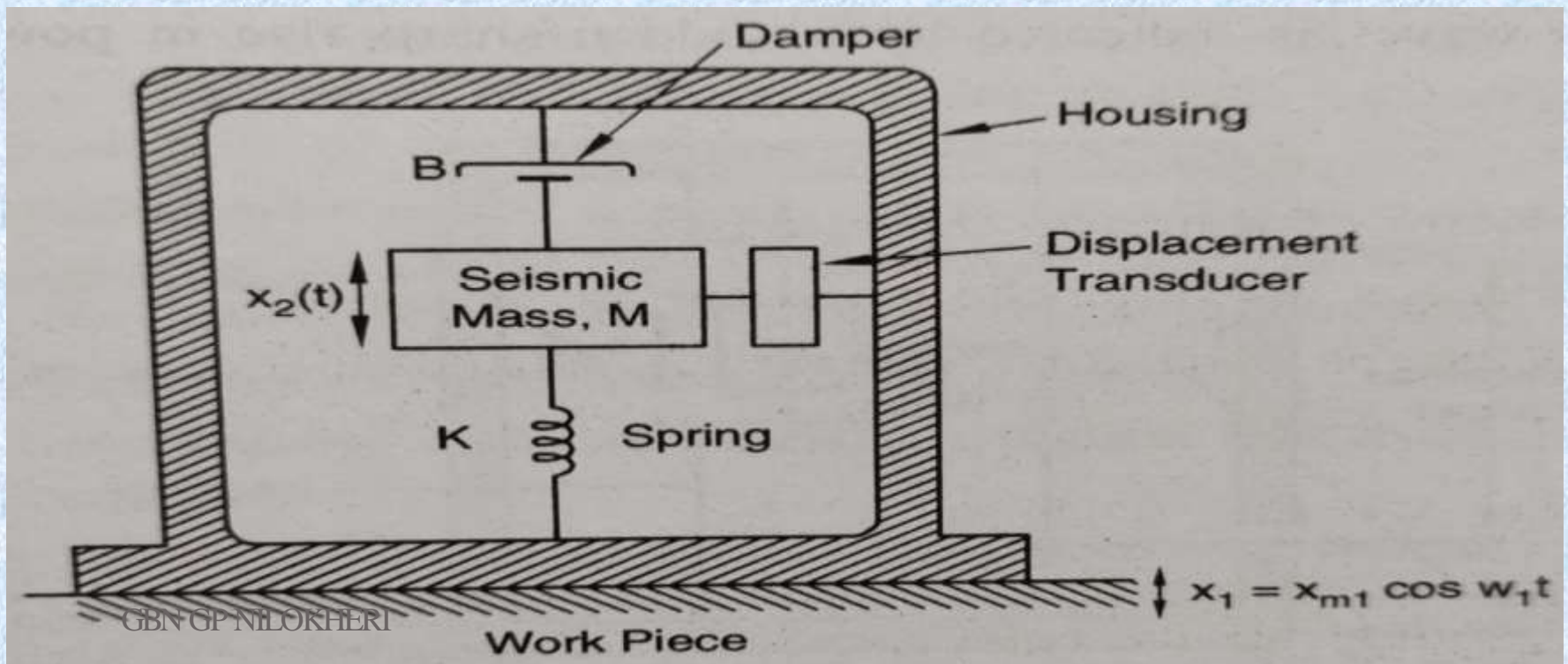

- The mass has the tendency to remain fixed in its spatial position so that the vibrational motion is registered as a relative displacement between mass and housing frame.
- This displacement is sensed and indicated by an appropriate transducer.
- The seismic transducer may be used in two different modes :
- (i) Displacement mode, and (ii) Acceleration mode.
- The mode to be selected depends upon the proper selection of mass, spring and damper combinations.

- In general, a large mass and a soft spring are suited for displacement mode measurements,
- while a relatively small mass and a stiff spring are used for acceleration mode measurements.
- A seismic-vibration transducer should be used for measurement of displacement amplitude at frequencies substantially higher than its natural frequency.
- **If the instrument is to be used for acceleration measurements (called accelerometer), the input frequency should be much lower than the natural frequency of the accelerometer.**
- **The most important transducer for vibration, shock and general purpose absolute motion is the accelerometer.**

Types of Accelerometers

- The variety of accelerometers used results from different applications with varied requirements of range of natural frequency and damping.
 - The specification sheet for accelerometer gives the natural frequency, damping ratio, and a scale factor which relates output with the acceleration input.
1. Potentiometric Type Accelerometer
 2. LVDT Accelerometers
 3. Piezo-electric Accelerometers

Potentiometric Type Accelerometer

- The seismic mass is attached to the wiper arm of resistance potentiometer.
- The relative motion of the mass with respect to the transducer frame is sensed either as a change in resistance or as a change in voltage output (if the potentiometer is used as potential divider).
- The damping may be provided by filling the housing of the accelerometer completely with a viscous fluid or it may be provided by a dashpot.
- Proper damping is necessary because it increases the range of frequencies over which the transducer may be used.

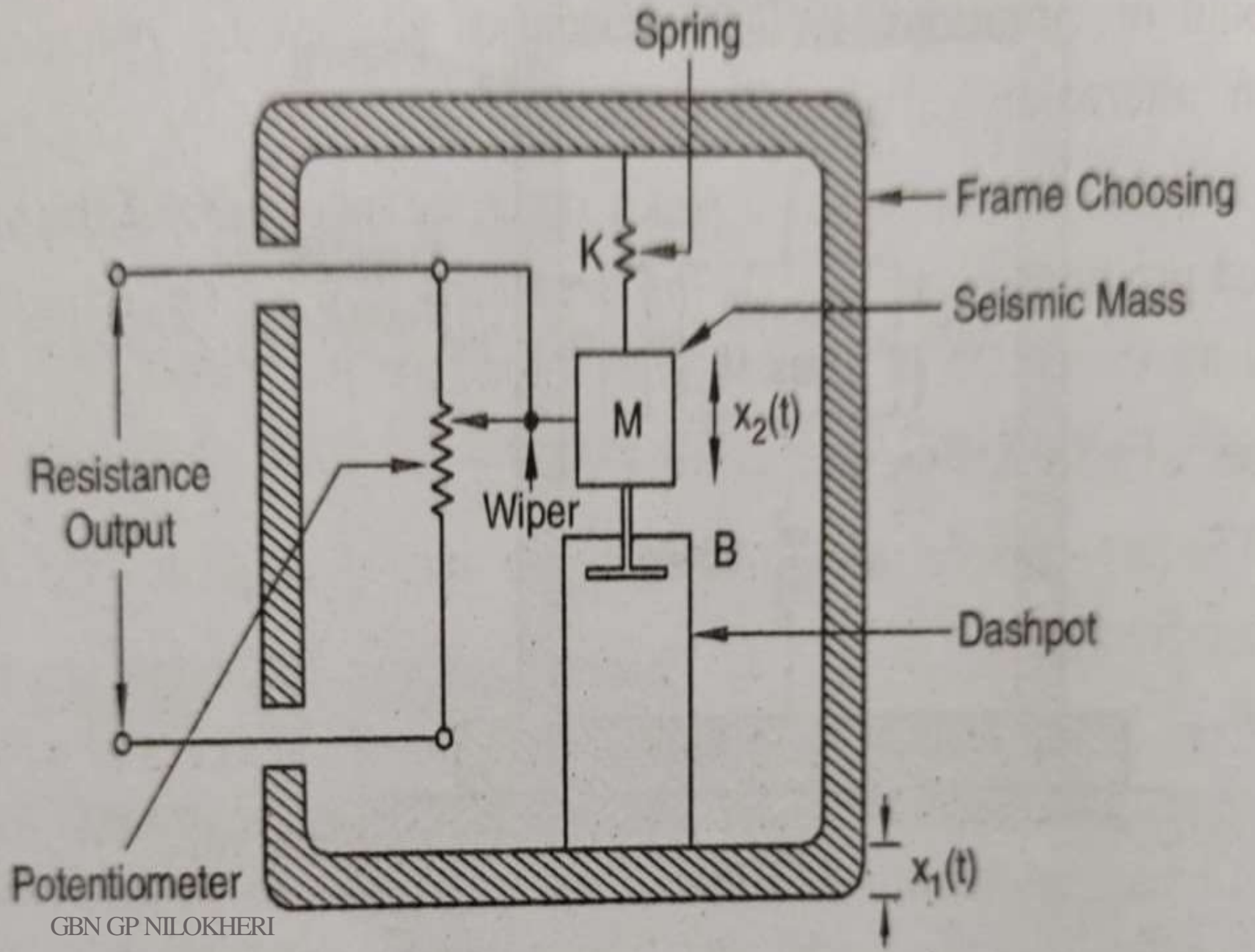

- The major drawbacks of a seismic accelerometer using resistance potential divider are its limited resolution and a rather low natural frequency.
- Its application is limited to input frequencies lower than 50 Hz.
- The instrument also gives errors on account of its sliding contacts.

Thank you